

**Japan Aerospace Exploration Agency**



**Institute of Space and Astronautical Science**

---

**BepiColombo  
Mercury Magnetospheric Orbiter [MMO]**

**MMO  
Mission Data Processor  
Interface Requirement Document  
(MMO-MDP-IRD)**

(JX-MMO-MDP-0001)

Version 1.52

29 June 2010

---

**JAXA/BepiColombo Project Office**

Institute of Space and Astronautical Science (ISAS)  
Japan Space Exploration Agency (JAXA)  
3-1-1 Yoshinodai, Sagami-hara, Kanagawa 229-8510, JAPAN  
Fax: +81-42-759-8456

## CHANGE LOG (改訂記録)

VER.	DATE	ITEMS
0.99	24 Apr 2008	Pre-final Version
1.0	8 May 2008	Fist Version
1.01	8 May 2008	Change: 7.0-2, 7.0-3, 7.0-4, 7.0-5, 7.0-6, 9.1.0-1
1.02	17 May 2008	Change: 5.3.1.0-1, 5.3.2.0-1, 9.1.0-1, B-8
1.03	29 Jun 2008	Change: 4.2.0-1, Appendix-A, B5(1) B8(1)
1.04	1 July 2008	Change: 5.1.2.0-2, 5.3.0-3, 5.3.1.0-4, 5.3.1.0-5, 5.7.0-2, B2, B5(1)
1.05	2 July 2008	Change: B2, B5(1), B8
1.1	5 Aug. 2008	Change: 5.5.0-1, 5.5.0-5, B8B8
1.11	11 Sep 2008	MEFISTO/SORBET info update
1.21	9 Jan 2009	Change: 4.3.0-7T
1.22	14 Feb 2009	Change: 5.2.2.0-2 R Appendix: ENA, MDM, MEFISTO, MGF-I, MGF-O, MSASI
1.23	14 Feb 2009	Change: B9 Appendix: MEFISTO, MGF-O
1.3	14 May 2009	Change: B-2(CommandBuffer) MEA1/2,MIA,MSA,HEP-ele,HEP-ion,EWO Change: B-2(HK Buffer) MEA1/2,MIA,MSA,MDM, Change: B-2(TI Register) MEA1/2,MIA,MSA Change: B-2(Mission Data Buffer) MEA1/2,MIA,MSA Change: B-2(Memory Load/Dump) MEA1/2,MIA,MSA Change: B-5 MEA1/2,MIA,MSA,MDM,MSASI,EWO,HEP-I,HEP-e Add:B-9(Format to/from PI tasks in MDP)
1.31	28 May 2009	Change: A-1 (Contact Person List) B-9(Format to/from PI tasks in MDP)
1.32	15 June 2009	Change: B-5 (Mission Data Plan) -- MEA B-9(Format to/from PI tasks in MDP) -- MEA
1.4	4 Dec. 2009	New: 4.2.0-3, 4.2.0-4 (TimeOut value of SpW Link Initialization [for 2MHz link]) 4.2.0-5 (Link disconnect value [for 2MHz link])
1.41	7 Dec. 2009	Minor typo corrections in 4.2.0-3, 4.2.0-5
1.42	28 Dec. 2009	B-1. Compliance Plan – Format
1.43	20 Jan. 2010	Update of B-2. based on I-ICD
1.44	29 Jan. 2010	Add: 6.1.0-4 (Delay time between safety mode start to Turn-Off) MEA: Update of B-2. based on I-ICD
1.5	12 March 2010	<b>5.1.2.0-2 R:</b> Max CMD length: <22B for MACRO / TimeLine CMDs <b>B-5.</b> MSA – TLM packet size <b>B-9.</b> Format to/from PI tasks in MDP --- “Report packet” > “OneShot packet”
1.51	19 May 2010	4.1.0-6 R: SpW connection - Grounding 5.5.2.0-2 D: MEM-dump – length (512B - fixed) 7.0-2 D: Command Format to Application is Changed (All data is transfered) B-5. MSASI – TLM packet size B-9. Format to/from PI tasks in MDP (2) MDP Telemetry for Data Dump -- minor update (4) SDRAM Assignment -- fix for FM (5) DMC-DR Assignment: User-HK -- fix for FM
1.52	29 June 2010	<b>B-9. Format to/from PI tasks in MDP</b> (1)MDP Command for Data Dump -- updated for FM (2)MDP Telemetry for Data Dump -- FM-Header definition <b>(TBR)</b> (4)SDRAM Assignment -- fix for FM (MSASI: slight reduce)

Current ICD Version from each team [9 April 2010]

	Submission date	Link : definition	speed from MDP	speed to MDP
MEA1/2	100123	Plan-C	2.0 +-0.02MHz	2MHz
MIA	091229	Plan-C(&B)	2.0 +-0.02MHz	4MHz
MSA	100309	Plan-C(&B)	2.0 +-0.02MHz	4MHz
HEP-e	091229	Plan-C	2.0 +-0.02MHz	2MHz
HEP-i	091229	Plan-C	2.0 +-0.02MHz	2MHz
ENA	100104	Plan-C	2.0 +-0.02MHz	2MHz
MGF-O	100111	Plan-B	2.0 +-0.02MHz	2.4576MHz
MGF-I	100107	Plan-C	2.0 +-0.02MHz	2.097 +-0.012MHz
EWO-E	091229	Plan-C(&B)	2.0 +-0.02MHz	4.2MHz
EWO-B	091229	Plan-C(&B)	2.0 +-0.02MHz	4.2MHz
SORBET	091229	Plan-C	2.0 +-0.02MHz	2MHz
MEFISTO	100112	Plan-C	2.0 +-0.02MHz	2MHz
MSASI	100409	Plan-C	2.0 +-0.02MHz	4MHz
MDM	100108	Plan-C	2.0 +-0.02MHz	2MHz
MASTWPT-E	100108	Plan-C	2.0 +-0.02MHz	2MHz

(Plan-A) Link from MDP to payload	(old)	2.0 +-0.02 MHz
	(new)	4.0 +-0.04 MHz
(Plan-B) Link from Payload to MDP	(old)	2.0 +-0.02 MHz in min
	(new)	enough larger than 2MHz
(Plan-C) Both 2MHz is OK.	(old)	'AutoStart' mode
[see 4.2.0-1]	(new)	'LinkEnable' mode

**Provision of SpW IP Core**

<b>Japan</b>	<b>Provision</b>	<b>from “SpW user group in Japan”</b>
<b>Europe</b>	<b>Provision</b>	<b>from Star-Dundee (&amp; Univ. Dundee)</b> (for MGF-O, MEFISTO-E, SORBET, MEA) JAXA is making direct contract with UoD for the procurement of SpW IP core.
	<b>Support</b>	<b>from Star-Dundee (&amp; UoD)</b>

**REVISED PAGE LIST (after Ver.2.0)**

pp.	Revision	pp.	Revision	pp.	Revision	pp.	Revision

## Table of Contents (目次)

1	Scope of Application	(適用範囲)
2	Applicable Document	(適用文書)
3	Interface Description	(インターフェイス概要)
4	Definition of Communication Interface	(通信インターフェース定義)
4.1	Physical Layer / Signal Layer	(物理層 / 信号層)
4.2	Exchange Layer	(通信層)
4.3	Packet Layer	(パケット層)
4.4	Endian	(エンディアン)
5	Command / Telemetry Service Definition	(テレメトリ・コマンドサービス規定)
5.1	Command	(コマンド)
5.1.1.	Command timing	
5.1.2.	Command Format	
5.2	HK data transmission	(HK データ収集)
5.2.1	HK data timing	
5.2.2	HK data format	
5.3	Mission Data transmission	(ミッションデータ収集)
5.3.1	Mission data timing	
5.3.2	Mission data format	
5.4	Mission Data transmission – Exception [PW/EWO]	
5.5	Memory Load / Dump	(メモリロード・メモリダンプ規定)
5.5.1	Memory Load Format	
5.5.2	Memory Dump Format	
5.6	Sun Pulse / Time Distribution	(Sun Pulse・時刻通知規定)
5.7	Memory MAP	
6	Interface Error Treatment	
6.1	Safety Mode Transition	(安全モード移行)
7	Telemetry / Command Format with the Ground	
8	EM (and FM) Integration Test	
8.1	Test Items	
8.2	Test Schedule	
9	GSE (MDP Emulator)	
9.1	Definiton and Function	
Appendix-A	Contact Point: Engineering Managers	
Appendix-B	Data requested to the Payload team	
B-1.	Compliance Plan	
B-2.	Address Map	

- B-3. Command Plan: for RMAP Write to the CMD Buffer**
- B-4. HK Data Plan: for RMAP Read from the HK Buffer**
- B-5. Mission Data Plan: for RMAP Read from Mission Data Buffer**
  - (1) Definition of Timing**
  - (2) Mission Data Format**
- B-6. Memory Load / Dump Definition**
- B-7. Safety Mode**
  - (1) Definition of Safety mode**
  - (2) Definition of Safety-transition CMD**
  - (3) Detection method of the Emergency**
- B-8. EM Test Plan**
  - (1) Test Plan**
  - (2) Proposal of the Schedule for EM integration test**

## 1 Scope of Application (適用範囲)

### 1.0-1 D

本規定書は、Mission Data Processor (MDP) に SpaceWire インターフェイスで接続される Payload 機器を対象とする要求項目を定義する。

This document defines the requirement for payloads that connect to the MDP instruments by Space-Wire interface.

### 1.0-2 D

以下の Payload 機器の有する SpW-I/F に適用される。

The requirement is applied to the Space Wire Interface in following payloads;

#### [To MDP/DPU1]

<MGF / MGF-O>	IWF / OeAW (Austria)
<MPPE / MEA>	CESR-CNRS (France)
<MPPE / MSA , MIA, ENA>	Meisei Elec. (Japan)
<MPPE / HEP-i , HEP-e>	MHI (Japan)

#### [To MDP/DPU2]

<MGF / MGF-I>	SHI (Japan)
<PWI / EWO>	MHI (Japan)
<PWI / SORBET>	Obs. de Paris (France)
<PWI / MEFISTO>	KTH / IRF-Uppsalla (Sweden)
<MSASI>	Meisei Elec. (Japan)
<MDM>	Meisei Elec. (Japan)
<MAST/WPT-E>	NIPPI (Japan)

## 2 Applicable Document (適用文書)

### 2.0-1 D

- ECSS-E-50-12A SpaceWire - Links, nodes, routers and networks
- ECSS-E-50-11 Draft.F Remote Memory Access Protocol
- JX-MMO-C0005 MMO Component Electrical Design Criteria
- JX-MMO-C0007 MMO Telemetry / Command Design Criteria

### 3 Interface Description

### (インターフェイス概要)

3.0-1 D

MDP は、Fig. 3.1 に示すように、合計 16 個の Payload 機器と接続する。  
 The MDP connect to 16 payloads by Space Wire in Fig. 3.1.

3.0-2 F

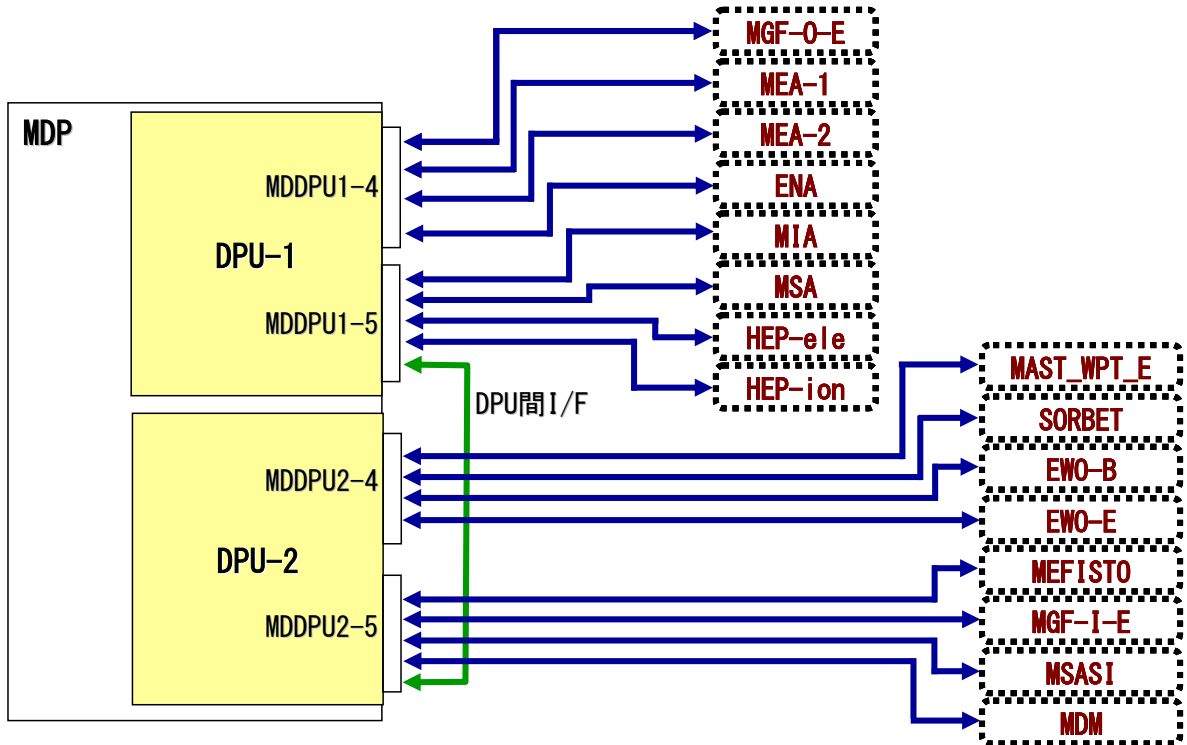

Fig. 3.1 MDP-Payload SpaceWire Interface design

3.0-3 D

MDP と各 Payload 間は Point-to-Point 接続とし、そのインターフェイスは基本的に以下の規定に従う。  
 本規定に対し、MDP-Payload 間インターフェイス個別仕様となる箇所を次項以降に記載する。

It makes point to point connection between the MDP and each payload. The interface between the MDP and payload follows the following regulation documents basically. An individual specification for the interface between the MDP and a payload is defined in next sub-section.

- ECSS-E-50-12A                      SpaceWire – Links, nodes, routers and networks
- ECSS-E-50-11 Draft.F              SpaceWire - Remote Memory Access Protocol



## 4 Definition of Communication Interface (通信インターフェース定義)

### 4.1 Physical Layer / Signal Layer (物理層 / 信号層)

#### 4.1.0-1 D

SpaceWire の標準的なコネクタピンアサインを、Fig. 4.1 に示す。

Standard pin assignment is shown in Fig. 4.1 for Space Wire interface connector.

#### 4.1.0-2 R

Payload は、標準ハーネスとの接続のため、これに従うか、変換コネクタを用意すること。

Payload shall use this specification or prepare the conversion connector in order to connect with standard harness.

#### 4.1.0-3 F

Contact number	Signal name
1	Din+
2	Sin+
3	Inner shield
4	Sout-
5	Dout-
6	Din-
7	Sin-
8	Sout+
9	Dout+

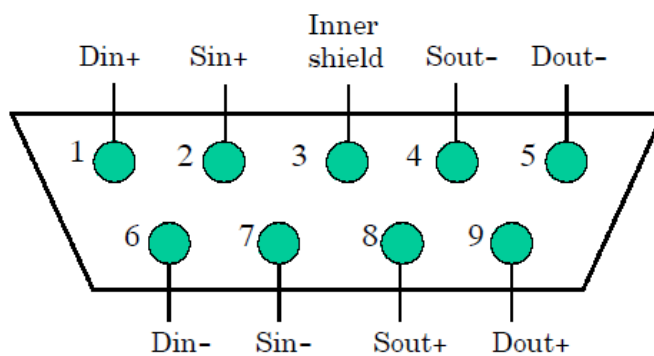

Viewed from rear of receptacle or front of plug.

Fig. 4.1 Standard pin assignment of the SpW connector for Payloads  
 (u-Sub 9pin: Socket type) [Ref. ECSS-E-50-12A]

#### 4.1.0-4 R

Payload は、以下のインターフェース条件に従うこと (Fig. 4.2)。相違点は、I-ICDに記述し、MDP チームへ直接申告のうえ、調整すること。

The payload shall keep the specification and condition for the interface between the MDP and itself as the followings. Diffent points should be described in I-CD, and define clearly with the MDP team.

- (1) Line driver / receiver : LVDS (TIA/EIA-644)
- (2) Output differential signal level : “0” -600mV < V<sub>AB</sub> < -100mV  
: “1” +100mV < V<sub>AB</sub> < +600mV
- (3) Termination type : Shunt Termination
- (4) Electrical instrument : Twist pair shield wire
- (5) Electrical instrument length : 10 m or less
- (6) Pull up Voltage : V<sub>cc</sub> = +3.3V (Nominal)
- (7) Pull up Resistance : R<sub>1</sub> = 12kΩ (Nominal)
- (8) Input Resistance : R<sub>2</sub> = 100Ω (Nominal)
- (9) Pull down Resistance : R<sub>3</sub> = 5kΩ (Nominal)

#### 4.1.0-5 D

The I/F of MDP is as follows:

*I/F Chip	UT54LVDS031LV (driver)
	UT54LVDS032LV (receiver)
*Driver	Supply voltage 3.3V
	High-level max1.650V
	Low-level min0.925V
	Centered around +1.2V (not 2.5V)

#### 4.1.0-6 R

MDP-Payload 間の SpaceWire 接続は、電気設計基準書 [MMO-C-EDC: JX-MMO-C0005] 10.1(2) (10.1.0-12/13/14) に従って接地すること。

SpaceWire connection shall follow the definition of 10.1(2) [10.1.0-12/13/14] in MMO Component Electrical Design Criteria [MMO-C-EDC: JX-MMO-C0005].

なお、ワイヤハーネスのシールドは、下記の旧 MDP-IRD 規定 (Fig. 4.2) に従ってもよい。

Shields of wireharness to the 2<sup>nd</sup>-common ground (COM2) can follow the past MDP-IRD definition (Fig. 4.2).

(1) Inner Shield: LVDS driver 側は、COM(2)に接続する。

LVDS reciever 側は、接続しない。

The inner shield of LVDS driver should connect to COM2

The inner shield of LVDS receiver **should not** connect to anywhere.

(2) Outer Shield: Payload 側は、接続しない。

The outer shield of wireharness **should not** connect to the payload side.

4.1.0-7 F

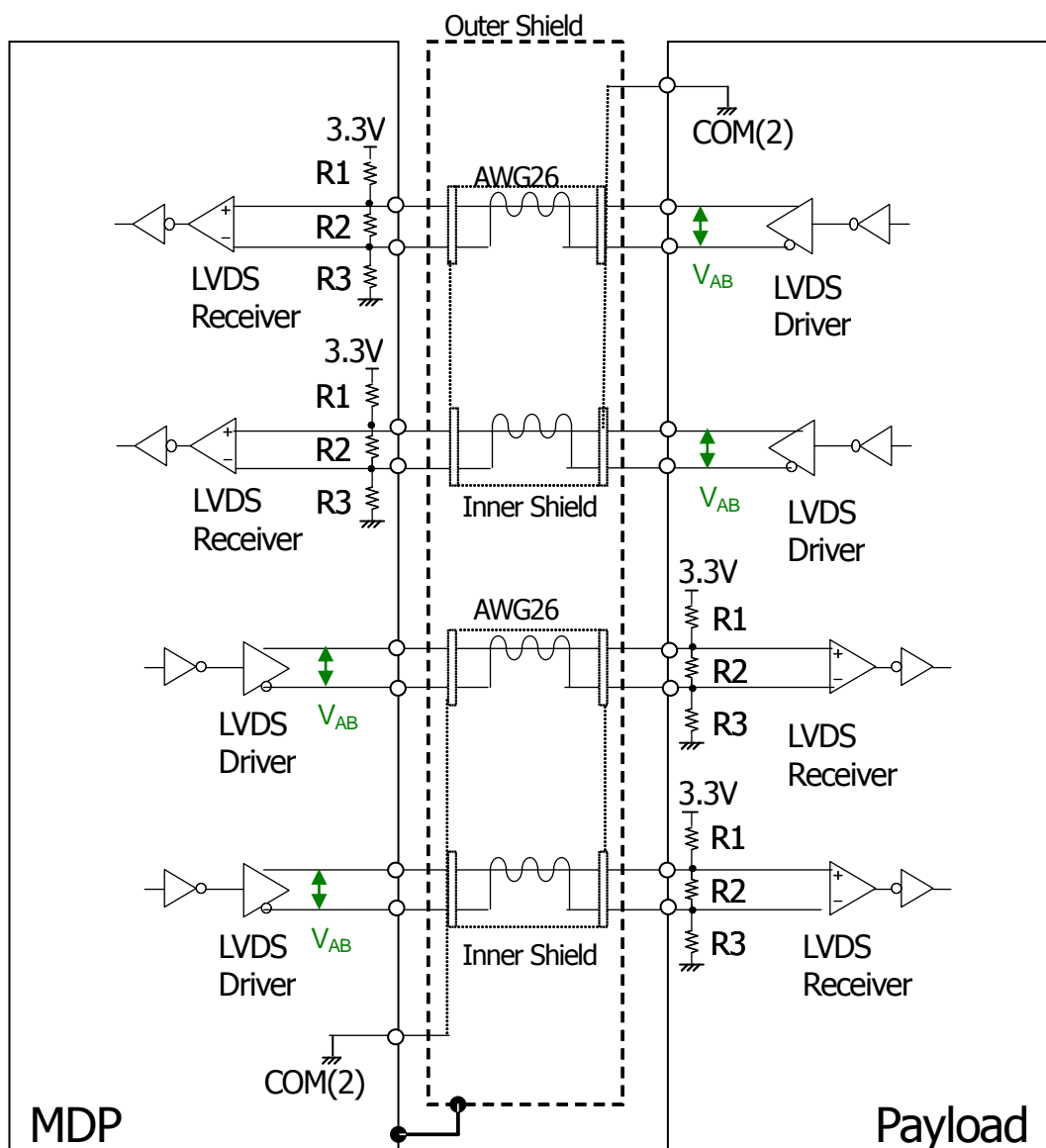

Fig. 4.2 インターフェイス回路仕様  
 Interface Circuit Definition

## 4.2 Exchange Layer (通信層)

### 4.2.0-1 R

Payload は、初期リンク、通常リンク共に、MDP と合意したリンク速度に対応すること。SpW の設定を、”Link Enable”モードとすること。

The payload shall support and keep the link speed range on SpaceWire. Both initial link and nominal link with “LinkEnable” mode.

<Possible range of the link speed>

\* from MDP to Payload : 1.980 ~ 2.020 MHz  
\* from Payload to MDP : 1.980 ~ 4.400 MHz

### 4.2.0-2 R

Payload は、リンク速度は初期リンク、通常リンクとも固定すること。  
通信中の速度変更は実施しない。

The payload should use the fixed link speed all time. The MDP *does not* support the change of the link speed between the MDP and the payload. It means that the initial link speed is equal to the nominal link speed.

### 4.2.0-3 R

MDP に接続する全機器は、次の SpW Link 初期化における TimeOut 定義において、以下の値へ設定すること。

For all instruments connected to the MDP, following values described in Fig. 4.4.0-4 shall be used for ‘timeout’ at SpW link Initialization.

---

* ‘Started > ErrorReset’	STD: 12.8 usec >> <u>32 usec</u>
* ‘Connecting > ErrorReset’	STD: 12.8 usec >> <u>32 usec</u>

Notice:	Nom:	<u>32us</u> ( 64cycles of 2MHz)
	Min:	<u>29.09us</u> (64cycles of (2MHz + 10%))
	Max:	<u>36.67us</u> (65cycles of (2MHz - 10%)).

---

(Standard definition: in Sec.8.5 [State Diagram] of ECSS-E-ST-50-12C)

4.4.0-4 F

Fig. 4.4.0-4 Data Send Scheme for the Payload

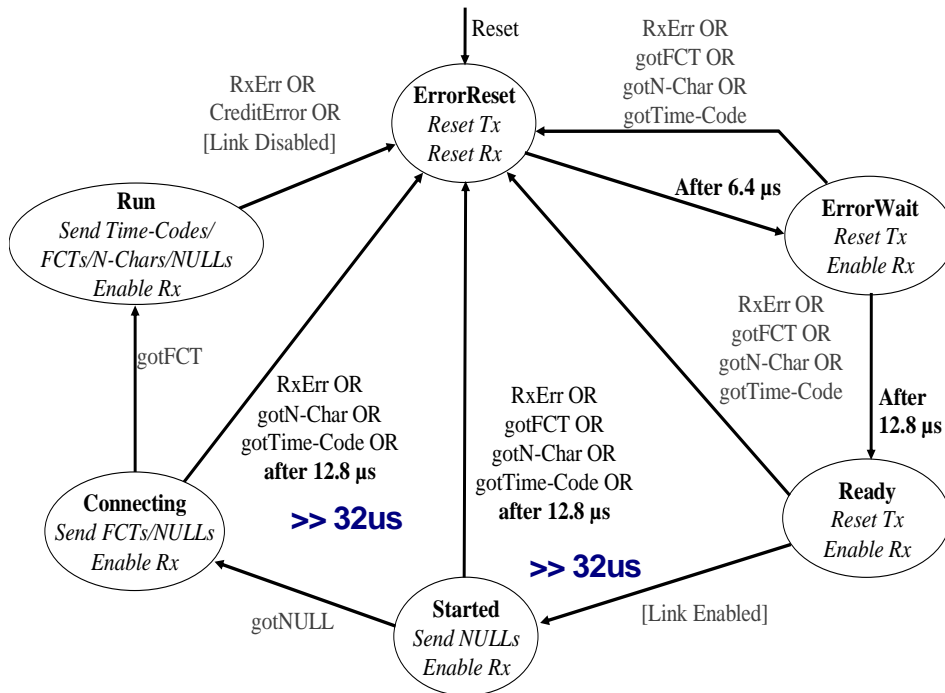

4.2.0-5 R

MDPに接続する全機器は、次の SpW Linkにおける Disconnect Timing 定義において、以下の値へ設定すること。

For all instruments connected to the MDP, following values shall be used for the Disconnect Timing of SpW link.

-----  
 [The SpW-node that has >2MHz system clock]

Nom: 850ns  
 Min: 727ns (8cycles of (10MHz + 10%))  
 Max: 1667ns (3cycles of (2MHz - 10%))

[The SpW-node that has only 2MHz system clock]

Nom: 850ns  
 Min: 909ns (i.e. 2cycles of 2MHz + 10%)  
 Max: 1667ns (i.e. 3 cycles of 2MHz - 10%)

-----  
 (Standard definition: in Sec.8.11.2 [Disconnect timing] of ECSS-E-ST-50-12C)

### 4.3 Packet Layer (パケット層)

#### 4.3.0-1 R

**Payload は、MDP から発行される、以下の RMAP Command を必ず受信すること。**

The payload shall designe the command interface that receives RMAP commands surely.

- **Time Code** Sun-Pulse timing [cf. Sec. 5.6]
- **RMAP Write Command** CMD write, Memory load [cf. Sec. 5.1, 5.5, 5.6]
- **RMAP Read Command** HK/Mission data requirement, Memory read [cf. Sec. 5.2, 5.3, 5.5]

#### 4.3.0-2 D

MDP は、これ以外の RMAP Command を送信しない。特に、Read Modify Write Command は、使用されない。

The MDP send only the above RMAP commands. The MDP should not send and use "Read Modify Write Command" defined in the document *ECSS-E-50-11 Draft.F*.

#### 4.3.0-3 R

**Payload は、RMAP Command に対する Reply として、以下のみを MDP へ送信すること。**

The payload shall only send the reply packets defined as follows;

- **RMAP Write Reply** (CMD answer back)
- **RMAP Read Reply** (HK/Mission data send)

#### 4.3.0-4 D

(Exception) EWO-E および EWO-B は、ミッションデータ送信のため、MDP へ RMAP Write Command 送信を実施する。この通信は、Ack を要求してはならない。

(Exception) EWO-E and EWO-B send RMAP Write Commands to the MDP in order to send mission data to the MDP. The EWO-E/-B should not request the ACK packet to the MDP when the RMAP Write Commands are sent.

#### 4.3.0-5 R

**Payload は、RMAP における「Logical Address 指定方式」に対応すること。**

**但し、「Path Address 指定方式」をサポートする必要は無い。**

Payload shall use "Logical Address". The MDP does not support the Path-Address.

#### 4.3.0-6 R

**Payload は、MDP が Table 4.1 および 4.2 に従って付する RMAP Header を受信するとともに、これに対応する RMAP Header を付した RMAP Reply を送信すること。**

The payload shall receive and support the RMAP packet including the Header defined in **Table 4.1** and **Table 4.2** surely. And then, the payload shall send the RMAP reply packet according to the Header to the MDP.

4.3.0-7 T

**Table 4.1 : Header Definition of RMAP Packet from MDP**

Item	Parameter
Destination Logical Address	See "Table 4.2" 1対1接続のため、本アドレスのCheckは要求しない。 (The check of this address does not be required. It is point to pint connection with MDP.)
Destination Key	H'00
Source Logical Address	See "Table 4.2"
Transaction Identifier (TID)	[HK data] MSB='1' (No Fixed value) [Mission data] MSB='0' Others: MDPは、設定した送信個数分、 Read Command送信ごとに1インクリメント。 The MDP add one when RMAP Read Command is sent to the payload.
Others	See ECSS-E-50-11 Draft.F

4.3.0-8 T

**Table 4.2 : Payload Logical Address**

Payload	Logical Address	CCSDS APID (Node ID+Component Extention Bits)
MDP-DPU1	H'20	H'18
MDP-DPU2	H'20	H'20
MDP-DPU1	MEA1	H'28
	MEA2	H'30
	MIA	H'38
	MSA	H'40
	HEP-ele	H'48
	HEP-ion	H'50
	ENA	H'58
	MGF-O	H'60
MDP-DPU2	MGF-I	H'68
	MDM	H'70
	MSASI	H'78
	EWO-E	H'80
	EWO-B	H'88
	SORBET	H'90
	MEFISTO	H'98
	MAST/WPT-E	H'A0

[cf. MMO Telemetry / Command Design Criteria (MMO-C-TCDC)]

## 4.4 Endian (エンディアン)

### 4.4.0-1 R MDP-Payload 間通信は、ビッグエンディアンで行うこと。

The communication with the MDP shall be by the big-endian.

### 4.4.0-2 D MDP から Payload へのデータ送信仕様を、Fig. 4.3 に示す。

Fig.4.3 indicates that the specification of the sending data form the MDP to the payload.

### 4.4.0-3 D MDP による Payload からの受信データ格納仕様を、Fig. 4.4 に示す。

Fig. 4.4 indicates that the specification of the data storage in the MDP.

### 4.4.0-4 F

Fig. 4.3 Data Send Scheme fo the Payload

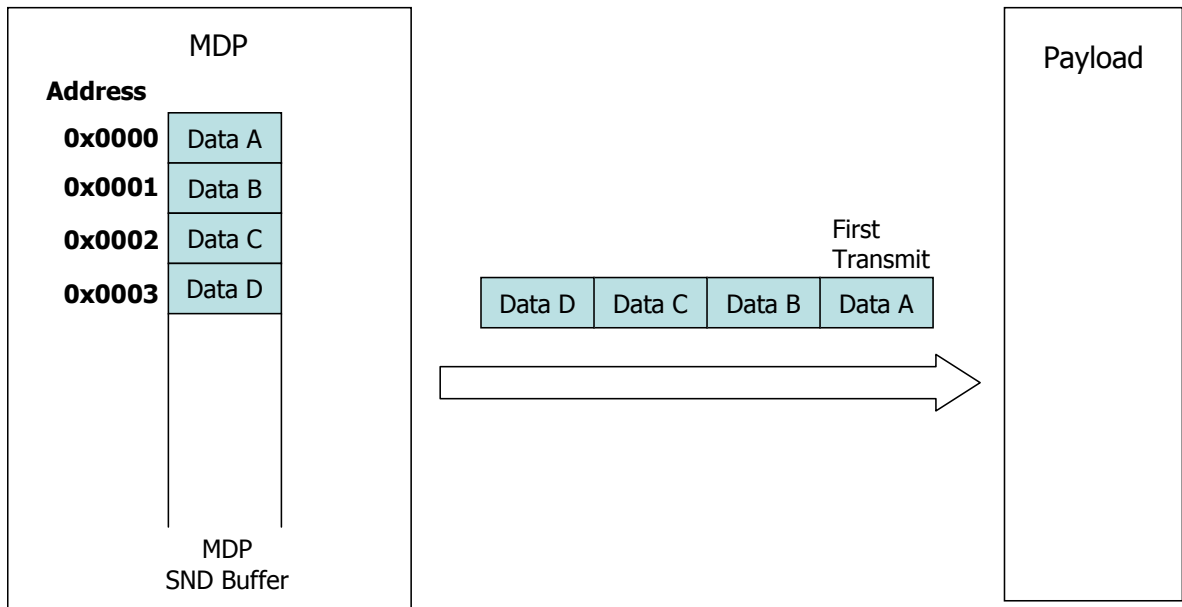

### 4.4.0-5 F

Fig. 4.4 Data Receive Scheme from the Payload

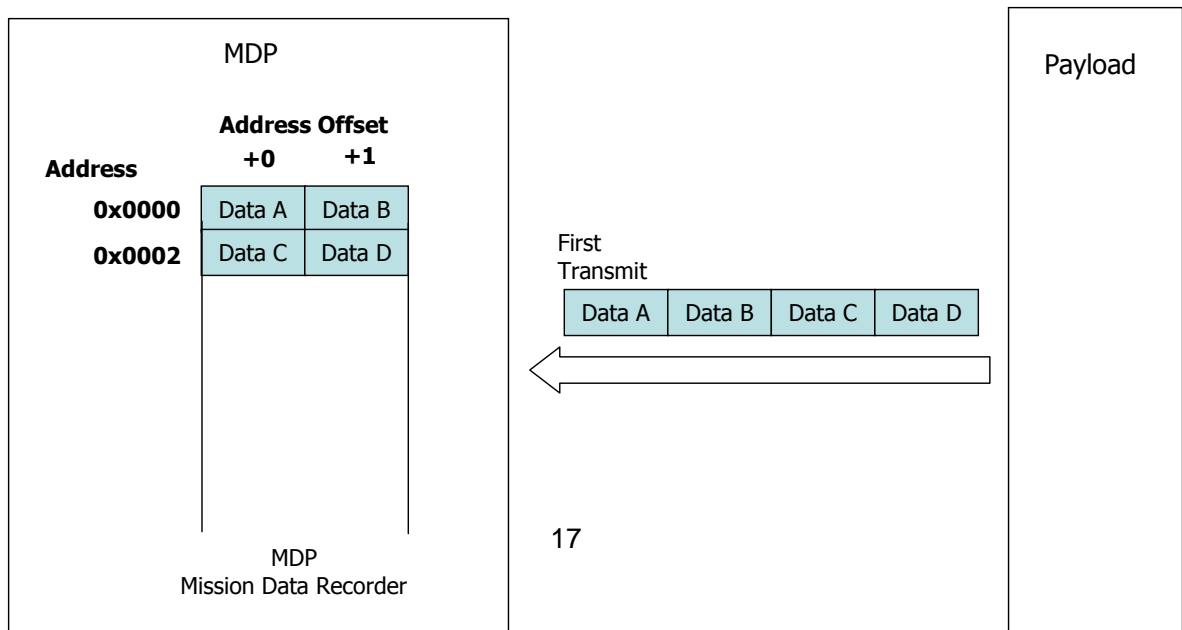



4.4.0-5 D

SpaceWire 内のビットストリームは、ECSS-E-50-12A の規定に従い Least Significant Bit First とする (Fig. 4.5)。

The bit-stream on SpaceWire is defined "Least Significant Bit First" according to ECSS-E-50-12A in Fig. 4.5.

4.4.0-6 F

Fig. 4.5 SpaceWire Bit Stream Specification

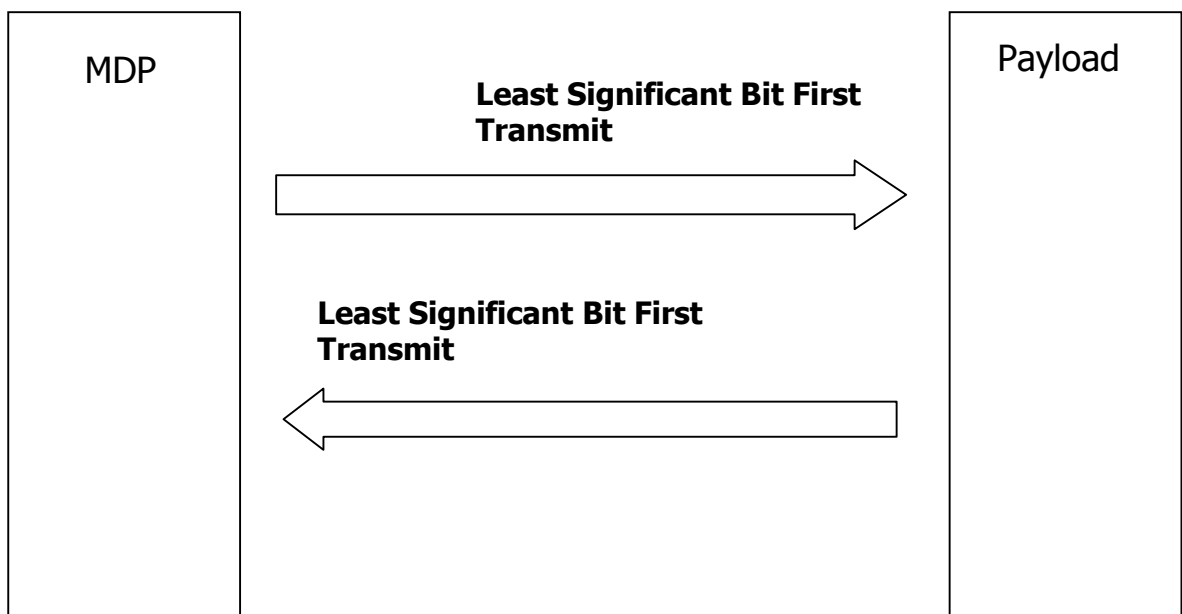

## 5 Command / Telemetry Service Definition (テレメトリ・コマンドサービス規定)

### 5.1 Command

#### 5.1.0-1 D

MDP は、コマンド送信を、Payload に RMAP Write Command を発行することで行う。

The MDP send commands to the payload using the RMAP Write Command on SpaceWire.

#### 5.1.0-2 R

**Payload は、RMAP Write Command の送信先として、163 bytes 長 の単一固定アドレスの「コマンドバッファ領域」を用意し、そのアドレスを MDP へ ICD を介して申告すること。この「コマンドバッファ領域」は、全コマンドについて共通に用いなければならない。**

The payload shall reserve the command buffer area (**163 bytes**) that is fixed address in the memory map in the payload for the RMAP Write Command from the MDP. The memory address is specified in the I-ICD. This "command buffer area" must be used in common about all the commands.

#### 5.1.0-3 D

MDP は、コマンド送信用 RMAP Write Command として、以下の設定を採用する (**Fig. 5.1**)。

The MDP set conditions for RMAP Write Command as follows; (see **Fig, 5.1**)

- Non-Verify (0)
- Ack (1)
- Increment

#### 5.1.0-4 D

MDP は、コマンド送信として、「コマンドバッファ領域」以外のアドレスへの直接書込を行わない。

The MDP should not support writing data directly to any memory address in the payload except for command buffer area.

#### 5.1.0-5 D

MDP は、RMAP Write の失敗などによってコマンドが確実に伝わらなくても、自動再送は行わない。

The MDP does not support re-sending the command to the payload automatically when the command does not be reached to the payload.

5.1.0-6 F

Fig. 5.1 Definition of RMAP Write Command (for Command from MDP)

Destination Logical Address	Protocol Identifier	Packet Type, Command, Source Path Addr Len	Destination Key
Source Logical Address	Transaction Identifier (MS)	Transaction Identifier (LS)	Extended Write Address
Write Address (MS)	Write Address	Write Address	Write Address (LS)
Data Length (MS)	Data Length	Data Length (LS)	Header CRC
Data	Data	Data	Data
Data	Data	Data	Data
Data	Data CRC	EOP	

Last byte transmitted

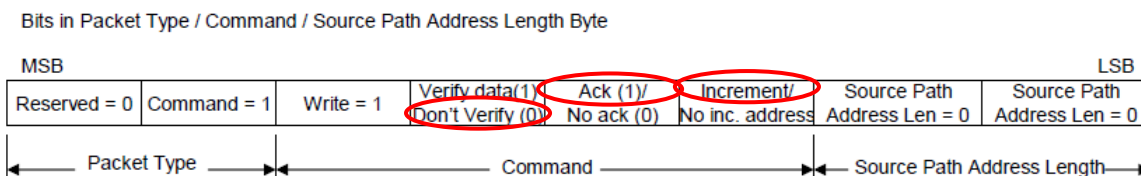

5.1.1. Command timing

5.1.1.0-1 D

MDPは、自身の内部タイミングを利用して、Fig. 5.2の規定に従ってPayloadへのコマンド送信を行う。このタイミングは、Sun Pulse Timingとは同期しない。間隔は、最短 875msec である。

The MDP send a command to the payload according to Fig. 5.2. This sending timing is not be synchronized with the Sun-pulse (Index-pulse) timing. The minimum interval is 875m sec.

5.1.1.0-2 R

Payload は、以下のタイミング規定に従うこと。

The payload should support (follow) the following timing regulation.

(1) RMAP Write Command による「コマンドバッファ領域」へのコマンド書込タイミングをモニターすること。

The payload keeps a watch the timing when a command written in the command buffer area by RMAP Write Command.

(2) Command の「コマンドバッファ領域」への書き込みを完了してから 63ms 以内に、MDP への RMAP Write Reply を送信完了すること。

The payload should send the RMAP Write Reply packet to the MDP within 63 msec when a command had received in the command buffer area from the MDP by the RMAP Write command.

(3) 最短の Command-Command 間隔である 875ms 以内に、次回コマンドが受信できる状態とすること。

The payload should become the condition that the next command can be received within 875 msec which are the shortest Command interval.

(4) コマンドバッファの読出しは、コマンド誤読を避けるため、MDP からの RMAP Write Command 受信中に行わないよう、調停機能等により設定すること。

The payload should control the read out timing from command buffer in order to avoid

reading the command buffer during receiving command data from the MDP.

5.1.1.0-3 F

Fig. 5.2 Command Transmission Timing from MDP

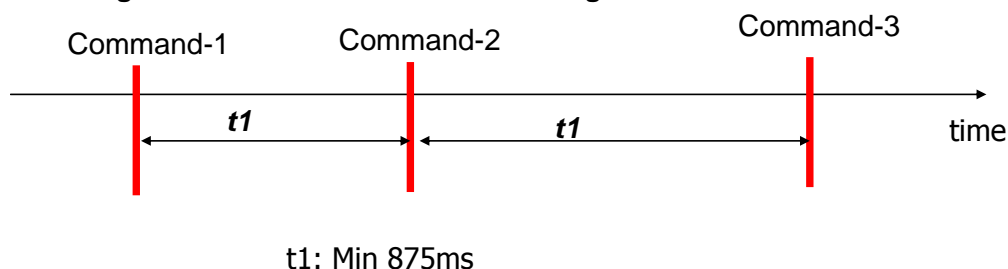

## 5.1.2. Command Format

### 5.1.2.0-1 D

MDP から Payload へのコマンドは、CCSDS format を使用しない (Ref. **Sec. 7**)。

It does not use the CCSDS format between the MDP and the payload. (Ref. **Sec. 7**)

### 5.1.2.0-2 R

MDP から Payload が受信する CMD は、以下の規定に従って独自に定め、MDP および System へ I-ICD を介して申告すること。

The command format is defined by each payload in I-ICD according to the following;

- (1) コマンド長: RMAP Header、CRC を含めて **180 bytes** 以下。なるべく短いものとする。  
この場合、Fig. 5.1 の "Data" サイズは、**163 bytes** 以下となる。

The length of command is less than **180 bytes** including RMAP Header and CRC. Shorter command is recommended. The length of data in Fig. 5.1 is less than **163 bytes**.

- (2) コマンドは、「スクリプトタイプ」とし、Payload 側でデコードする。「レジスタの直接アクセス」は行わない。

Command should be 'Script type'. It should be decoded by Payload. 'Register-type access' should not be used, in order to avoid the miss operation.

(Example : 4Byte-CMD) [Address 2bytes] [Word 2bytes] "0x0102 0x0304"

- (3) 機器側 CMD バッファに書き込まれる最長 CMD 長は、MACRO (cf. 3.1.1.1 in MMO-C-TCDC) ないし Time-Line (cf. 3.3.2.1 in TIME-LINE) の場合、**< 22 Bytes** とする。

For the CMD used in MACRO [cf. 3.1.1.1 in MMO-C-TCDC] or Time-Line [cf. 3.3.2.1 in MMO-C-TCDC], the maximum length of CMD written into the CMD-BUFFER of the payload shall be **less than 22 Bytes**.

## 5.2 HK data transmission

## (HK データ収集)

### 5.2.0-1 D

MDP は、HK データ収集を、Payload の固定アドレスへに RMAP Read Command を発行して行う。  
 The MDP will collect HK data from the fixed memory address in each payload using RMAP Read Command.

### 5.2.0-2 R

Payload は、RMAP Read Command へ渡すデータエリアとして、128 bytes 長 の単一固定アドレスの「HK データバッファ領域」を用意し、そのアドレスを MDP へ HCD を介して申告すること。

Payload は、このアドレスのデータを、RMAP Read Reply によって MDP に返送する。

The payload should reserve the HK data buffer area (128bytes) that is fixed address in the memory map in the payload for the RMAP Read Command from the MDP. The payload should send the HK data in that buffer area using the RMAP Read Reply packet. The memory address is specified in the I-ICD.

### 5.2.0-3 D

MDP は、HK data request 用 RMAP Read Command として、以下の設定を採用する (Fig. 5.3)。

The MDP set conditions for RMAP Read Command for HK data as follows; (see Fig. 5.3)

- Increment
- Transaction Identifier (TID): MSB='1'. Others = '0'

### 5.2.0-4 F

Fig. 5.3 Definition of RMAP Read Command (for HK data request from MDP)

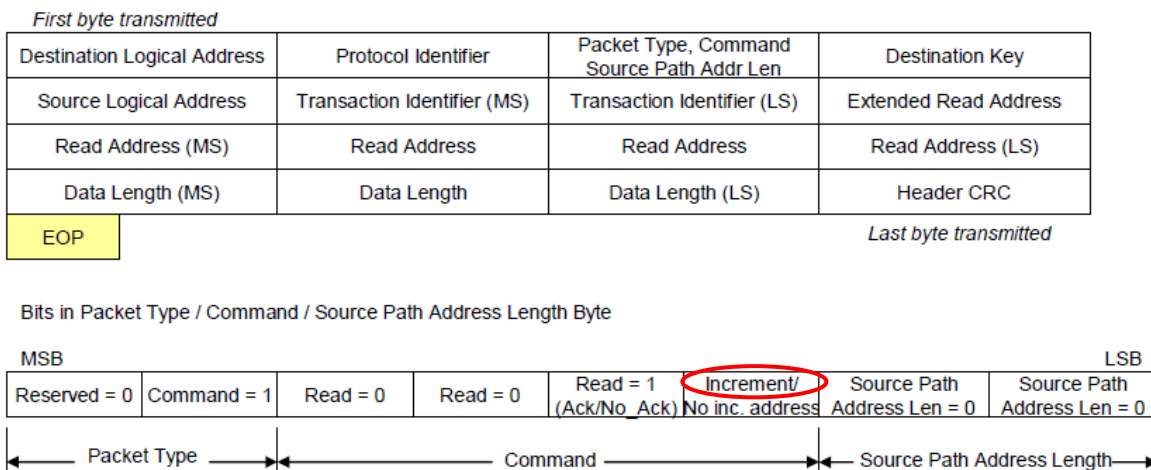

## 5.2.1 HK data timing

### 5.2.1.0-1 D

MDP は、自身の内部タイミングを利用して、Fig. 5.4 の規定に従って Payload への HK Read 送信を行う。このタイミングは、Sun Pulse Timing とは同期しない。

間隔は、最短 **875msec** である。

The MDP send a RMAP Read Command for HK to the payload according to Fig. 5.4. This sending timing is not be synchronized with the Sun-pulse (Index-pulse) timing. The minimum interval is **875 msec**.

### 5.2.1.0-2 R

Payload は、以下のタイミング規定に従うこと。

The payload should support (follow) the following timing regulation.

- (1) RMAP Read Command による「HK データバッファ領域」からの読出し要求タイミングをモニターすること。

The payload keeps a watch the timing when the HK request (collection) from the MDP by RMAP Read Command for HK. (Polling)

- (2) RMAP Read Command 受信を認識してから 63ms 以内に、MDP への RMAP Read Reply について HK データ送信を完了すること。

The payload should send the HK data using RMAP Read Reply packet to the MDP within 63 msec when HK request had received from the MDP by the RMAP Read command for HK.

- (3) 最短の HK 読出し間隔である 875ms 以内に、次回 HK データを送信できる状態とすること。

The payload should become the condition that the next HK request can be received and the HK data can be sent within 875 msec which are the shortest HK collection interval.

- (4) HK データバッファの更新は、MDP からの RMAP Read Command 受信が重なった際でも、調停機能等によりデータ化け等の不具合を発生しないよう設定すること。

The payload should control the HK update timing in HK buffer area to avoid the conflict between reading the HK and writing the HK for update.

### 5.2.1.0-3 F

Fig. 5.4 RMAP Read Command : Timing Definition of HK data collection

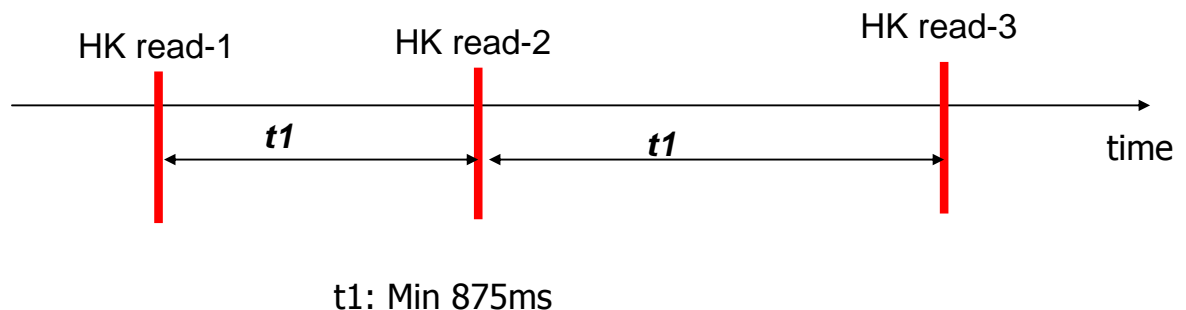

## 5.2.2 HK data format

### 5.2.2.0-1 D

MDP への HK data は、CCSDS format を使用しない。

It does not use the CCSDS format for HK data between the MDP and the payload.

### 5.2.2.0-2 R

MDPへ送信するHKデータは、以下の規定に従って独自に定め、MDPおよびSystemへ HCD を介して申告すること。

The HK format between the MDP and each payload is defined by each payload in I-CD according to the following;

- (1) データ長: 128 bytes 以下の固定長。

The fixed length of HK data is less than 128 bytes.

- (2) 特定アドレスには、単一の意味を持たせる。いわゆる「サブコミ」は禁止する。

Each address and bit shall has a single meaning.

(3) 以下を含めること。

The HK data must include the following information counters;

- 4Bit, or more  **RMAP Error counter**

**RMAP Error** の回数を示す。具体的にどのエラーを Count するか示すこと。但し、少なくとも **RMAP Header CRC Error** を含むこと。

Show the number of RMAP Error (includes at least RMAP Header CRC Error). Please define the kind of counted errors in MDP-IRD.

- 4Bit, or more  **Command Receipt Counter**

“Memory Write” 等を含めた、全 **RMAP Write** パケットの受信数とする。

for all **RMAP Write** including “Memory Write” etc.

(3') 以下を含めることを推奨する。

The HK data is recommended to include the following information;

- **Answer back of the Command executed in the Payloads**

ex) **CMD Counter**

**CMD AnswerBack**

etc.

(4) 先頭から N Byte 目まで: **DMC** および **System** に認識させるべき重要ステータスを配する。**N** は、原則として **20 以下** とし、**HCD** を介して申告する。これ以外は、**MDP** が「**ミッションステータスパケット**」として編集し、**ミッションデータ**の一環として伝送する。

N bytes from the head of the HK: It arranges the important status which it should make the **DMC** and **System** recognize. **N** is equal to or less than **20 bytes**. Those bytes should be specified in the **I-ICD**. The others of **HK** bytes are edited by the **MDP** not for the **HK** packet in the system but as ‘the mission data packets’.

### 5.3 Mission Data transmission

(ミッションデータ収集)

#### 5.3.0-1 D

MDP は、ミッションデータ収集を、Payload の固定アドレスへ RMAP Read Command を発行して行う。

The MDP will collect mission data from the fixed memory address in each payload using RMAP Read Command.

#### 5.3.0-2 R

Payload は、RMAP Read Command へ渡すデータエリアとして、単一固定アドレスの「Mission データバッファ領域」を用意し、そのアドレスを MDP へ I-CD を介して申告すること。Payload は、このアドレスのデータを、RMAP Read Reply によって MDP に返送する。

The payload should reserve the mission data buffer area that is fixed address in the memory map in the payload for the RMAP Read Command from the MDP. The memory address is specified in the I-CD. The payload should send the mission data in that buffer area using the RMAP Read Reply packet.

#### 5.3.0-3 D

MDP は、ミッション data request 用 RMAP Read Command として、各 Payload ごとに以下の設定を個別採用する (Fig. 5.5)。Payload 側は、これに対応してどちらかに固定する。

The MDP set conditions of RMAP Read Command respectively for each payload as follows; (see Fig. 5.5). The payload should select "increment" or "No-increment" (FIFO-access).

- Increment or No-Increment (FIFO-access)
- Transaction Identifier (TID) : MSB= '0'

Others: 各シーケンス開始を0とし、Read Command 送信ごと1 インクリメント  
 Add one when the MDP send the RMAP Read Command.

#### 5.3.0-4 F

**Fig. 5.5 Definition of RMAP Read Command (for Mission data request from MDP)**

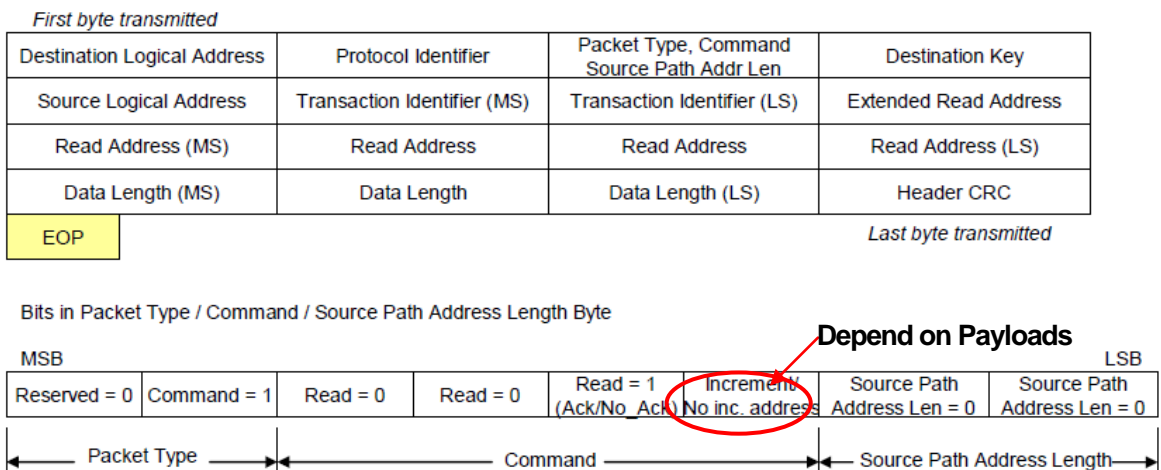



## 5.3.1 Mission data timing

### 5.3.1.0-1 D

MDP は、自身の内部タイミングを利用して、**Fig. 5.6** の規定に従って Payload への Mission Data Read 送信を行う。このタイミングは、Sun Pulse Timing とは同期しない。間隔は、Payload 毎に定義する。

The MDP send a RMAP Read Command for Mission Data to the payload according to **Fig 5.6**. This sending timing is not be synchronized with the Sun-pulse (Index-pulse) timing. The interval is defined each payload.

### 5.3.1.0-2 R

**観測時の Sun Pulse 間隔は、4.000 – 5.500 sec とする。**

The interval of Sun-pulse(Index-pulse) is defined **from 4.000 to 5.500 sec** when observation.

**Sun Pulse に同期してデータ生成する Payload は、最短間隔である 4.000 sec での動作で 5.3.1.0-3 の各パラメータを設定するとともに、上記の範囲で動作可能とすること。(例えば、Sun Pulse 単位でデータを生成する機器では、間隔がより空く場合、「無効パケット」を送信することとなる。)**

The payload that synchronizes with sun-pulse and generates mission data makes parameters for 5.3.1.0-3 with minimum interval of sun pulse **4.000 sec**. (If the interval of sun pulse is longer than 4 sec, the payload will send 'Empty packet' filled by specific values to the MDP.

**Sun Pulse 間隔が上記範囲を逸脱する場合でも、機器が危険な状態とならないことを保障すること。**

Payload shall not be critical status when Sun-Pulse interval is out of this condition.

### 5.3.1.0-3 R

**Payload は、5.3.1.0-4 の条件に基づき、Fig. 5.6 にある以下の 固定値 を、自己のタイミング規定として決定すること。この定義は、MDP へ HCD を介して申告すること。**

The payload should define itself timing parameters as follows according to the regulation in 5.3.1.0-4 and those parameters is specified in the HCD.

- |           |   |
|-----------|---|
| (1) $T_0$ | : Interval of the sequence                      |
| (2) $N$   | : Number of Mission data packet in one sequence |
| (3) $L$   | : Data size of a mission data packet            |
| (4) $T_1$ | : Shortest interval of mission data packet      |

**MDP へのミッションデータレートは、" $(N \times L) / T_0$ " で定義されることになる。  $T_1$  は、5.3.1.0-4 の条件に矛盾しない範囲で、任意に選択してよい。**

The data rate to the MDP is defined by  $(N \times L) / T_0$ .  $T_1$  can be selected based on the conditions specified in 5.3.1.0-4.

### 5.3.1.0-4 D

MDP は、各シーケンスごとに、ミッションデータ受信回数をカウントしている。このため、各シーケンス終了時刻に、シーケンス中の全ての RMAP Read Reply 受信が完了している必要がある。(完了しない場合、MDP に保存されるデータ並びに異常が出る。)

MDP counts the number of mission data packet during one sequence. At the end of each sequence, all RMAP Read Reply within this sequence should be finished. (If not, the payload data stored in the MDP will be partially collapsed.)

以下の手順で、各パラメータを設定することができる。

Payload can select each parameter by the following scheme:

**A. データ生成レート " $(N \times L) / T_0$ " に基づき、以下のパラメータを仮決定する。**

First, following parameters are assumed based on the data production rate ' $(N \times L) / T_0$ '.

\* L: Size of one packet

以下のいずれかの条件から、固定値を決定する。

Fixed value, specified by condition (a) or (b).

(a) A specific data size produced in the Payload

(b) Size of data buffer area in the Payload

\* N: Number of packet in one sequence

Fixed value: 1~34

\*  $T_0$ : Interval of each sequence

Fixed value: "1.000 sec", "2.000 sec" or "4.000 sec"

\* V: Link speed x 0.8 (bps)

Link speed: Fixed value "2 MHz" or "4 MHz"

Effective speed is about 'x 0.8' bps.

**B.  $T_1$  (ミッションデータ送信間隔) を決定する。**

Define  $T_1$  (Interval of each packet).

\* $T_1$ : as a fixed value: 1 ~ 256 msec (1.0msec step)

[Accuracy of the  $T_1$  in MDP is +/- 1%.]

**C. 「RMAP-Read CMD の間隔  $T_2$ 」の範囲を確認する。 $T_2$ とは、以下の範囲となる。**

Confirm the range of "the interval of RMAP-Read CMD  $T_2$ ". It is in (a) - (d).

<In the sequence>

(a)  $T_2 = T_1 + 1.3msec$

(b)  $T_2 = T_1 - 1.3msec$

<At the boarder of the sequence>

(c)  $T_2 = T_0 - T_1 \times (N-1) + 10 msec + 1.3 msec$  (= C(max) + A (max))

(d)  $T_2 = T_0 - T_1 \times (N-1) - 10 msec - 1.3 msec$  (= C(min))

**D. Payload は、最大・最小  $T_2$  を、ミッションデータバッファの「上書き」や「書込み中」等といった問題なく許容できること。(超えた場合、上書きによるデータ喪失が発生)。**

Payload should allow the "**shortest / longest interval  $T_2$** ", without the overwrite of mission data buffer nor the collision with buffer writing.

**E. Payload は、最小  $T_2$  のうちに、MDP への RMAP Read Reply 送信を完了できること。(これが満たされない場合、Payload はデータを送りきることができない。)**

Payload should finish the send of RMAP Read Reply packet, within '**shortest interval  $T_2$** ', after the receipt of RMAP Read Command. (If not, Payload can not finish the data send before the next packet start.)

**End of the RMAP Read Reply packet sending**

= LV + (The loss-time before the RMAP-Read-Reply packet start)

< **shortest  $T_2$**

5.3.1.0-5 D

(Ex-1) Data packet : 20kB, Production rare: '1 Spin' / 64 (= 62.5 – 85.9 msec)  
 <Ref> Averaged data rate:  $(N \times L) / T_0 = 2.56 \text{ Mbps}$   
 >> L: 20 kB N: 16 T<sub>0</sub>: 1 sec V: 4 MHz x 0.8 = 3.2Mbps  
T<sub>1</sub>: 60msec (+1%) (Possible value: 59.4 ~ 60.6 msec)  
 T2: Max  $T_0 - T_1 \times (N-1) + 11.3 = 111.3 \text{ msec}$   
 Min  $T_1 - 1.3 \text{ msec} = 58.7 \text{ msec}$   
 Time for 1 packet send :  $L/V = 6.25 \text{ msec}$   
 Max wait  $T_0 - T_1 \times (N-1) + 11.3 = 111.3 \text{ msec}$   
Requested payload design for allowable RMAP Read Interval ; 57 – 114 msec  
(It is possible by Double buffer in the payload.)

(Ex-2) Data packet : 100kB PoDUCTION rate : '1 spin' = 4-5.5sec  
 <Ref> Averaged data rate:  $(N \times L) / T_0 = 0.4 \text{ Mbps}$   
 >> L: 100 kB N: 1 T<sub>0</sub>: 2 sec V: 2 MHz x 0.8 = 1.6Mbps  
T<sub>1</sub>: --- msec (+1%)  
 T2: Max  $T_0 - T_1 \times (N-1) + 11.3 = 2.013 \text{ sec}$   
 Min  $T_0 - T_1 \times (N-1) - 11.3 = 1.087 \text{ sec}$   
 Time for 1 packet send :  $L/V = 62.5 \text{ msec}$   
 Max wait  $T_0 - T_1 \times (N-1) + 11.3 = 2.013 \text{ sec}$   
Requested payload design for allowable RMAP Read Interval ; 1.98 – 2.02 sec  
(It is possible by Single buffer in the payload)

(Ex-3 : MGF-O case) Data packet : 202B, Production rare: 125msec  
 (Averaged data rate:  $(N \times L) / T_0 = 13 \text{ kbps}$ )  
 >> L: 202 B N: 8 T<sub>0</sub>: 1 sec V: 2 MHz x 0.8 = 1.6Mbps  
T<sub>1</sub>: 125msec (+1%) (Possible value: 123.7 ~ 126.3 msec)  
 T2: Max  $T_0 - T_1 \times (N-1) + 11.3 = 137 \text{ msec}$   
 Min  $T_0 - T_1 \times (N-1) - 11.3 = 114 \text{ msec}$   
 Time for 1 packet send :  $L/V = 8 \text{ msec}$   
Requested payload design for allowable RMAP Read Interval: 110 - 140 msec  
(It is possible by Double buffer in the payload.)

5.3.1.0-6 R

**Payload は、以下のタイミング規定に従うこと。**

The payload should support (follow) the following timing regulation.

**(1) RMAP Read Command による「ミッションデータバッファ領域」からの読出し要求タイミングをモニターすること。**

The payload keeps a watch the timing when the mission data request (collection) from the MDP by RMAP Read Command for mission data. (Polling)

**(2) 最短のミッションデータ読出し間隔である T<sub>1</sub> 以内に、次回ミッションデータを送信できる状態とすること。**

The payload should become the condition that the next mission data request can be received and the mission data can be sent within T<sub>1</sub> which is the shortest mission data collection interval.

**(3) ミッションデータバッファの更新は、MDP からの RMAP Read Command 受信が重なった際でも、調停機能等によりデータ化け等の不具合を発生しないよう設定すること。**

The payload should control the mission data update timing in mission data buffer area to avoid the conflict between reading the mission data and writing the mission data for update.

5.3.1.0-7 F

**Fig. 5.6 各 SpW I/F 毎のミッションデータ収集タイミング定義**  
**Definition of Mission Data Accumulation Timing for each SpW I/F**

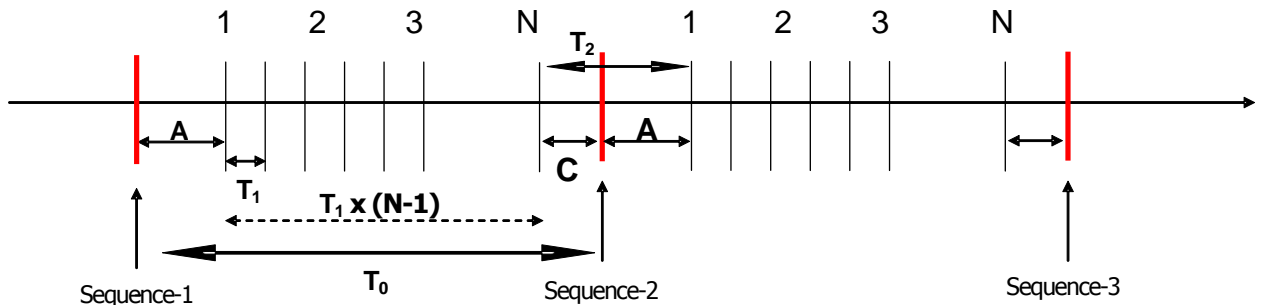

- N: Number of packet in each sequence
- $T_0$ : Interval of each sequence (1, 2, or 4 sec)
- $T_1$ : Interval of each Mission Data Packet (1~256msec, 1msec step)
- $T_2$ : Wait time at the sequence start (MAX:  $C+A[\max]+B[\max]$ , MIN:  $C - B[\max]$ )
- A: Interval from "sequence start" to "the 1<sup>st</sup> RMAP-Read CMD" from MDP (0~10msec)
- B: Zitter of "RMAP-Read CMD" timing from MDP (0~1.3msec)
- C: Interval from "the last RMAP-Read CMD" to the end of each sequence

**5.3.2 Mission data format**

5.3.2.0-1 D

MDP への Mission data は、CCSDS format を使用しない。Mission data packet は、MDP/DPU 内にある DPU-DS (data storage) に形成されるリングバッファ内に、一時蓄積される。

It does not use the CCSDS format for mission data between the MDP and the payload. Mission data packets are stored temporary ring buffered memory (255MB SDRAM for 8 payloads) in MDP/DPU.

5.3.2.0-2 R

MDP へ送信する Mission データは、以下の規定に従って独自に定める(Example: Fig. 5.7)。この Format は、MDP へ ICD を介して申告すること。

The payload shall define the mission data format, in I-ICD according to the following; (See example; Fig. 5.7)

- |                   |   |
|-------------------|---|
| (1) Data length   | FIXED   |
| (2) Data header   | Followings should be included (see Sec. 5.6.0-6)      |
| - TI (Time Index) | 32 bits (LSB: 1.95 msec resolution)<br>(MSB: 97 days) |

5.3.2.0-3 R

Payload は、無効データが含まれる packet には、その識別を明確に示すこと。以下を推奨する。

Payload shall show the sign for the packet which includes ineffective data. Following concepts are recommended:

- i) Data area: 各 Payload 毎に定義した Fill データ(例:0xFFFF) で、無効データ域を埋め

る。

Fill the ineffective area by 'fill data' (ex. 0xFFFF) defined by each payload

(Fig. 5.7, sample 1)

ii) Data header: 「有効データ数」「無効パケットの識別子」等を示す。

Show 'Number of effective data bytes' / 'Sign of effective/non-effective' etc.

(Fig. 5.7, sample 3)

(参考) 上記の解釈は、Payload チームが貢献して作成する「MDP 内プログラム」によって処理される。このプログラムは、Header で「Empty data」が含まれることを識別した場合、そのデータを棄却することで、計算負荷および Telemetry 削減を行う。

(Ref) Those data is treated by the MDP software with the contribution from each payload team. In order to reduce the load, MDP should easily identify the effective data or not.

5.3.2.0-4 F

Fig. 5.7 Mission Data Packet (example)

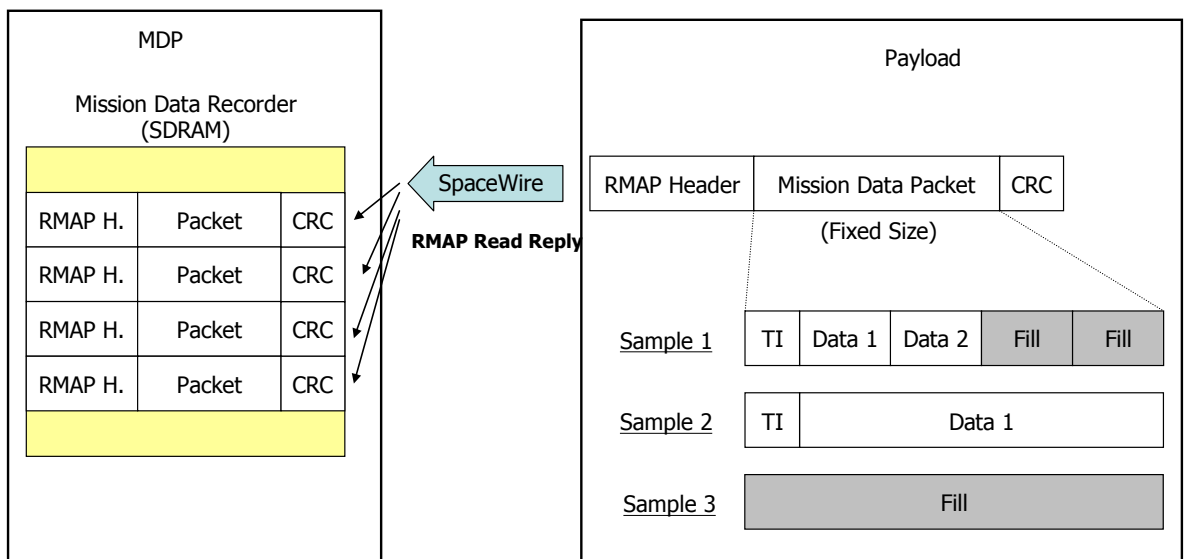

5.4 Mission Data transmission – Exception [PW/EWO]

5.4.0-1 D

PW/EWO のミッションデータ収集は、EWO から MDP へ RMAP Write CMD を発行することで行う。EWO が発行する RMAP Write Command は、(1) Non-Verify、(2) Non-Ack、(3) Increment 設定とする(Fig. 5.8)。

5.4.0-2 D

その他の点は、Sec. 5.3 の規定に従う。

5.4.0-3 F

Fig. 5.8 RMAP Write Command 設定 (EWO ミッションデータ送信)

Destination Logical Address	Protocol Identifier	Packet Type, Command, Source Path Addr Len	Destination Key
Source Logical Address	Transaction Identifier (MS)	Transaction Identifier (LS)	Extended Write Address
Write Address (MS)	Write Address	Write Address	Write Address (LS)
Data Length (MS)	Data Length	Data Length (LS)	Header CRC
Data	Data	Data	Data
Data	Data	Data	Data
Data	Data CRC	EOP	

*Last byte transmitted*

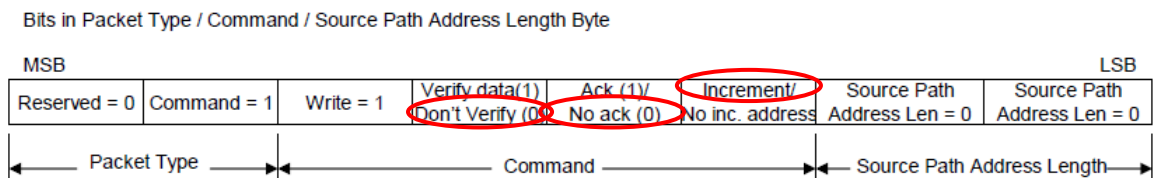

## 5.5 Memory Load / Dump (メモリロード・メモリダンプ規定)

5.5.0-1 D

本機能は、地上局から Payload の特定 Memory 領域に対するロード・ダンプを行うものである。MDP は、MDP 自身の内部タイミング(DMC からの Processing Frame Timing)を利用して Payload にメモリロード・メモリダンプを行う。Sun Pulse Timing とは同期しない。

This function is to load to and dump from the specific memory area of the Payload from the Ground.

The MDP has the function that “memory load” and “memory dump” for each payload using RMAP Read/Write command. This sending timing is not be synchronized with the Sun-pulse (Index-pulse) timing.

5.5.0-2 D

メモリロード・メモリダンプは、RMAP の Direct Memory Access 機能を利用する。

The function that “memory dump/load” uses the function of “Direct Memory Access”.in RMAP.

5.5.0-3 R

**Payload は、メモリロード・メモリダンプを要する領域に対し、RMAPによるDirect Memory Access を可能とすること。**

Payload should make Direct Memory Access by RMAP possible to the memory area which needs both memory load and memory dump. The amount of Load / Dump shall be minimized after the launch.

5.5.0-4 D

MDP は、メモリロード・メモリダンプ中には、「通常コマンド」および「ミッションデータ要求」を送信しない。(「緊急コマンド」および「HK データ要求」のみを送信する。)

The MDP does not send the normal command / Mission data request. (HK request and Emergency command are sent.)

5.5.0-5 R

総合試験およびフライト後に常用するメモリロード・ダンプは、内容およびアドレスエリアを、MDP へ I-ICD を介して申告すること。量および頻度は最小限とし、運用に与える影響を最小とする。本機能はあくまで例外である。メモリロードには CMD 機能、メモリダンプには TLM・HK機能の利用を推奨する。

For the memory load and dump function which is nominally used in the itegration test and after the launch, the contents and address area shall be sent to MDP though I-ICD. Amount and frequency of this operation shall be minimized, in order to shrink the operation requirement.

This function is exceptional operation. Payload should use the CMD dunction for Memory Load and the HK/TLM function for Memory Dump as much as possible.

5.5.1 Memory Load Format

5.5.1.0-1 D

メモリロード用 RMAP Write Command は、(1) Non-Verify、(2) No-Ack、(3) Increment 設定とする。(Fig. 5.9)

The condition of RMAP Write Command for memory load is (1) Non-Verify, (2) No-Ack and (3) increment. (See Fig. 5.9)

5.5.1.0-2 D

メモリロード 1 回につき、最大 239Bytes までロード可能とする。(RMAP Header 含めて 255Bytes 以下)。

The length of memory load is less than 239 bytes each memory load command. (It is less than 255 bytes including RMAP header)

5.5.1.0-3 F

Fig. 5.9 RMAP Write Command: For Memory Load

Destination Logical Address	Protocol Identifier	Packet Type, Command, Source Path Addr Len	Destination Key
Source Logical Address	Transaction Identifier (MS)	Transaction Identifier (LS)	Extended Write Address
Write Address (MS)	Write Address	Write Address	Write Address (LS)
Data Length (MS)	Data Length	Data Length (LS)	Header CRC
Data	Data	Data	Data
Data	Data	Data	Data
Data	Data CRC	EOP	

Last byte transmitted

Bits in Packet Type / Command / Source Path Address Length Byte

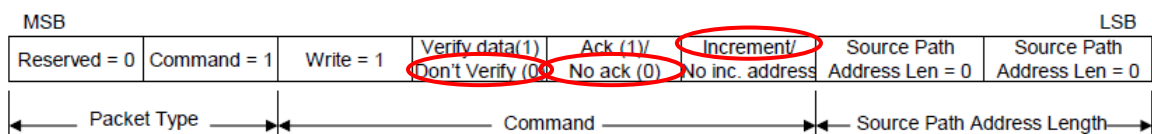

## 5.5.2 Memory Dump Format

### 5.5.2.0-1 D

メモリダンプ用 RMAP Read Command は、“Increment 設定”とする (Fig. 5.10)。

The condition of RMAP Write Command for memory load is “Increment”. (See Fig. 5.10)

### 5.5.2.0-2 D

メモリダンプ 1 回につき、512Bytes 固定でダンプ可能とする。

The length of memory dump is 512 bytes (fixed) by each memory dump command.

### 5.5.2.0-3 F

**Fig. 5.10 RMAP Read Command: Memory Dump**

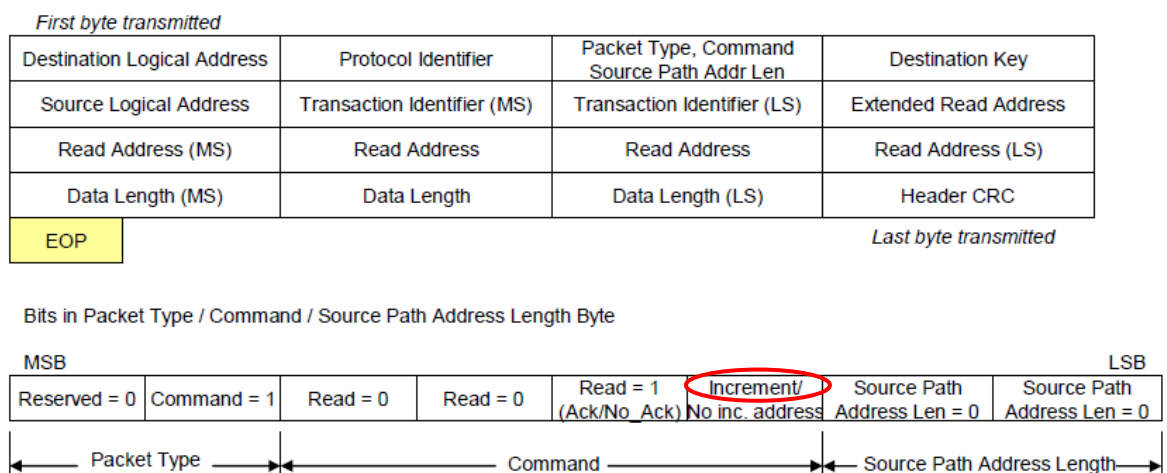

## 5.6 Sun Pulse / Time Distribution (Sun Pulse・時刻通知規定)

### 5.6.0-1 D

Payload への Sun Pulse Timing 通知は、SpaceWire TimeCode を利用して行う。TimeCode のカウンタ値は、Sun Pulse 毎にカウントアップする。(値に意味は無い。)

The Sun Pulse Timing notice to Payload does using SpaceWire TimeCode. The counter value of TimeCode is count-up every Sun Pulse. (There is not a meaning in the value.)

### 5.6.0-2 D

Payload への時刻通知は、固定アドレスに設ける「時刻データレジスタ」への RMAP Write Command 送信にて行う。内容は、32bits (LSB = 1.953ms)幅の「直前 Sun Pulse Timing の時刻」である。

The MDP send the information of time index to the fixed address (time index register) in each payload by RMAP Write Command. The content of time index is 32bits data (LSB = 1.953 m sec). This time index shows time of the last Sun Pulse Timing.

### 5.6.0-3 D

時刻配信用 RMAP Write Command は、(1) Non-Verify、(2) No-Ack、(3) Increment 設定とする (Fig. 5.11)。

The condition of RMAP Write Command for TimeIndex distribution is (1) Non-Verify, (2) No-Ack and (3) increment. (See Fig. 5.11)



5.6.0-4 F

**Fig. 5.11 RMAP Write Command: Sun Pulse Time Distribution**

Destination Logical Address	Protocol Identifier	Packet Type, Command, Source Path Addr Len	Destination Key
Source Logical Address	Transaction Identifier (MS)	Transaction Identifier (LS)	Extended Write Address
Write Address (MS)	Write Address	Write Address	Write Address (LS)
Data Length (MS)	Data Length	Data Length (LS)	Header CRC
Data	Data	Data	Data
Data	Data	Data	Data
Data	Data CRC	EOP	

*Last byte transmitted*

Bits in Packet Type / Command / Source Path Address Length Byte

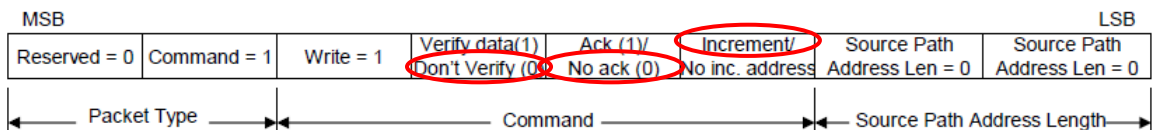

5.6.0-5 D

Sun Pulse Timing 通知及び時刻通知タイミングを、**Fig. 5.12** に示す。

**Fig 5.12** indicates the timing chart of Sun Pulse Timing and Time-Index distribution.

5.6.0-6 R

**Payload は、以下の規定に従うこと。**

The payload should support (follow) the following regulation.

- (1) 時刻配信用 RMAP Write を受けるための、「時刻データレジスタ」(4Bytes)を設けること。このアドレスは、HCD を介して MDP へ申告する。

The payload should reserve the TimeIndex data register (4bytes) that is fixed address in the memory map in the payload for the RMAP Write Command for Time Index distribution from the MDP. The memory address is specified in the I-ICD.

- (2) ミッションデータに、時刻情報を付すること。 (cf. 5.3.3.0-2)

The payload should include the TI (time index) in mission data. (Cf. 5.3.3.0-2)

-TI<sub>0</sub> MDP から受信した Sun Pulse 時刻の TI (32bit [LSB: 1.953 msec])

Time of Sun Pulse from the MDP

-TI<sub>1</sub> TI<sub>0</sub> からの経過時刻

Time from TI<sub>0</sub>

**Ex) - Time from TI<sub>0</sub> (16bit [LSB: 1.953 msec])**

**- Spin phase from the Sun Pulse**

5.6.0-7 D

MDP からの TI 更新は、Sun Pulse の受信の後となる。このため、TI<sub>0</sub> は、常に「ひとつ前の SunPulse」の時刻とすることを推奨する (**Fig. 5.13**)。

MDP send the TI packet after the Sun-Pulse distribution. Therefore, we recommend that TI<sub>0</sub> is based on one before the last Sun Pulse.(See **Fig. 5.13**)

5.6.0-8 F

**Fig. 5.12 Sun Pulse Timing and Time Distribution Command**

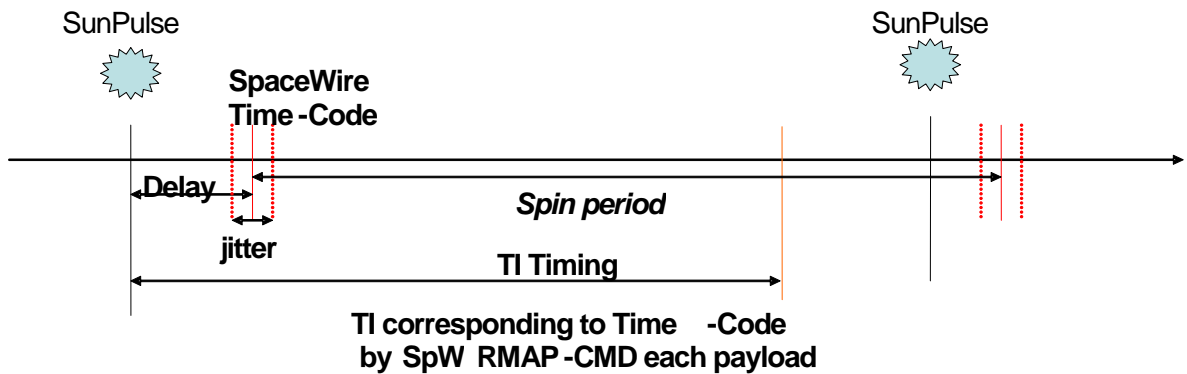

<Reference info: Definition of MSASI / MDP I/F>

- Delay < 100 usec
- Jitter < 10 usec
- TI Timing < 1sec

<Reference info: Definition of MSASI / AOS I/F>

- Precision of Spin period: < 100usec

5.6.0-9 F

**Fig. 5.13 Recommendation: Scheme of Payload Time Management**

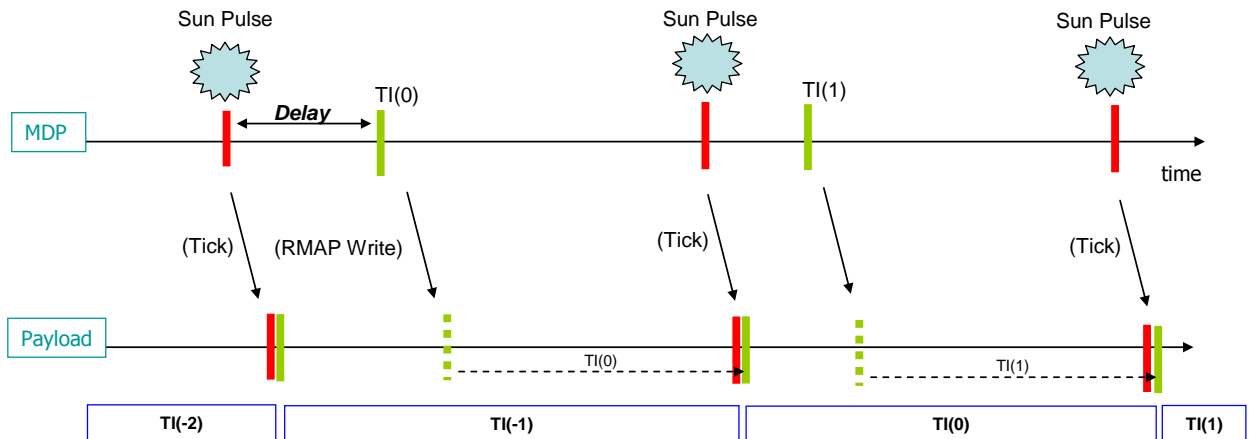

## 5.7 Memory MAP

5.7.0-1 R

**Payload** は、Table 5.1 に示す種類の固定アドレス領域群を確保すること。各領域のアドレスは、Table 5.1 の値を推奨する。この情報は、HCD を介して、MDP へ申告する。

The payload should reserve the fixed areas shown in Table 5.1. Each value is recommended to use the one in Table 5.1. The memory addresses are specified in the I-CD.

5.7.0-2 T

**Table 5.1 MDP-Payload I/F memory Map: Recommendation**

Start Address	End Address	Size	Name	Remark
0x0C00	0x0CA3	163Bytes	Command buffer	RMAP Write from MDP
0x0D00	0x0D7F	128Bytes	HK data buffer	RMAP Read from MDP
0x0E00	—	—	Mission data buffer	RMAP Read from MDP
0x0F00	0x0F03	4Bytes	TI Register	RMAP Write from MDP
Others			Memory Load	RMAP Write from MDP
Others			MemoryWrite	RMAP Read from MDP

## 6 Interface Error Treatment

### 6.0-1 D

MDP は、以下に示す Payload との通信異常を検出する。

The MDP detects following errors;

- (1) MDP: RMAP receipt error (cf. ECSS-E-50-11 Draft.F)
- (2) Payload: RMAP receipt error (by RMAP Reply packet from payloads)
- (3) MDP: Internal process error
- (4) RMAP Read Reply Time Out Error:

When all RMAP Read Reply packets are not received at the end of each sequence.

### 6.0-2 D

通信異常検出時の MDP 動作を下記に示す。

MDP Action with those errors.

- (1) CMD Write / Memory Dump

再送はしない。エラー情報は、MDP-HK データまたはエラーログにて地上局に通知する。

No send those again. Error info will be in MDP HK or Error log.

- (2) HK Read / Mission data Read

次回タイミングまで、収集コマンドを送信しない。エラー情報は、MDP-HK データまたはエラーログにて地上局に通知する。

No RMAP Read Command until the start of next sequence. Error info will be in MDP HK or Error log.

- (3) Memory Load / Time Distributon / Sun-Pulse (TimeCode)

MDP は、このエラーを検出しない。必要であれば、Payload 側でエラー情報を HK に出力すること。

MDP can not detect those. If it is needed, Payload should send the information by its HK.

### 6.0-3 D

6.0-2 (1)(2)に関して、MDP 内のアプリケーションソフトは、ミッションデータ管理情報を介して通信異常の有無を知ることができる。エラー処置が必要な場合、このルートで実施することができる。

MDP software can know the errors in 6.0-2 (1)(2). Error treatment is potentially possible by this route.

## 6.1 Safety Mode Transition

(安全モード移行)

### 6.1.0-1 R

Payload は、MDP から制御出来なくなった場合、各自でこれを検知し「安全モード」に移行すること。

The payload should change to the safty mode by itself, when the MDP can not control a payload.

### 6.1.0-2 D

「安全モード」とは、「急に電源 OFF されても、自身や他機器へダメージを与えない状態」である。

必要がない機器では、特にこのモードを用意する必要はない。

The safety mode is defined that even if the power is shutdown suddenly the payload does not give damages itself and the other instruments including spacecraft system. If there are no such status, the payload is not needed to prepare the safety mode.

(Ex) HV (>100V)	It should be turned
Extention etc.	It should not stop at the critical configuration.

#### 6.1.0-3 R

**Payload は、以下の方法で、MDP からの制御不能状態を検知すること。**

The payload should detect the condition that the MDP can not control itself as follows;

##### (1) MDP からの「安全モード移行コマンド」を受信すること。

When the command "Safty mode" is received

**安全モードを用意する Payload は、単一 CMD で実施される「安全モード移行コマンド」の実装を推奨する。**

'Single command' is recommended for the change into the Safety mode.

##### (2) MDP との SpaceWire リンク Disable (例えば、TimeCode の非送信)がある一定時間を超過したことを検出すること。

When elapsed time during Space Wire Link disable (ex. No TimeCode ffrom the MDP)

**このタイムアウト検出時間は、8~12 sec の範囲(2spin 分 + マージン)で Payload 毎に規定すること。検出方法は、各 Payload に一任する。**

Time-out should be set from 8-12 sec (2 spins + margine), based on the design of each payload.

#### 6.1.0-4 D

**各ペイロード PSU は、安全モード移行から下記に定める時間経過後、OFF される。**

**Each Payload PSU will be turn off after the Safety Mode transition with the time length defined in below.**

* MDM	[by MDM-PSU]
* MGF, EWO, AM2P, SORBET, MDM	[by MDP-IPD]
after "0 sec"	
* MEFISTO, MASTWPT-E	[by Motor-PSU, MDP-IPD]
After "60 sec"	
* MEA, MIA, MSA, HEP, ENA,	[by each PSU]
* MSASI	[by own PSU]
* PME	[by PME-PSU]
After "180 sec"	

MEA detect the SPW link failure.  
After 10s MEA will go automatically in Safety Mode (all the HV switched off).  
Within 1s, the PSU could switch off MEA.  
That means that 11 s after the SPW link failure the MEA sensors could be switched off.

MEFISTO will terminate the deployment (and HV) 15ms after link disconnect is detected but it will take 0.5s to reach a controlled stop (eg. slow down to 0 deploy rate) so It is ok to power MEFISTO off after ~1s.

## 7 Telemetry / Command Format with the Ground

7.0-1 D  
 MDP と Payload 間のテレコマフォーマットを示す。地上局にて作成するコマンドのフォーマットは、JX-MMO-C0006 MMO Telemetry / Command Design Criteria に従う。  
 COM/TLM format between the MDP and the payload is shown; Ground based TLM/COM format is defined in the document X-MMO-C0006 MMO Telemetry / Command Design Criteria.

7.0-2 D  
**(1) Command Format : “N + Address”: 16bit (Fixed)**  
 (MDP User application receives all CCSDS packet. [changed @ v1.51])

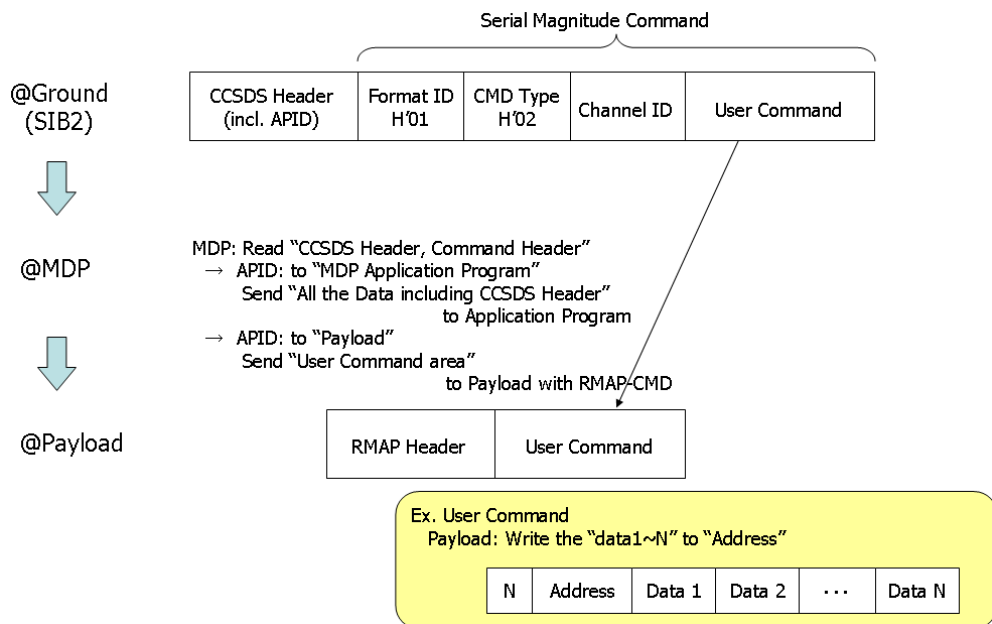

7.0-3 D  
**(2) Memory Load Format**  
 (1)を用いた Memory Load も可能である。但し、本 Format を用いたコマンド送信は禁止とする

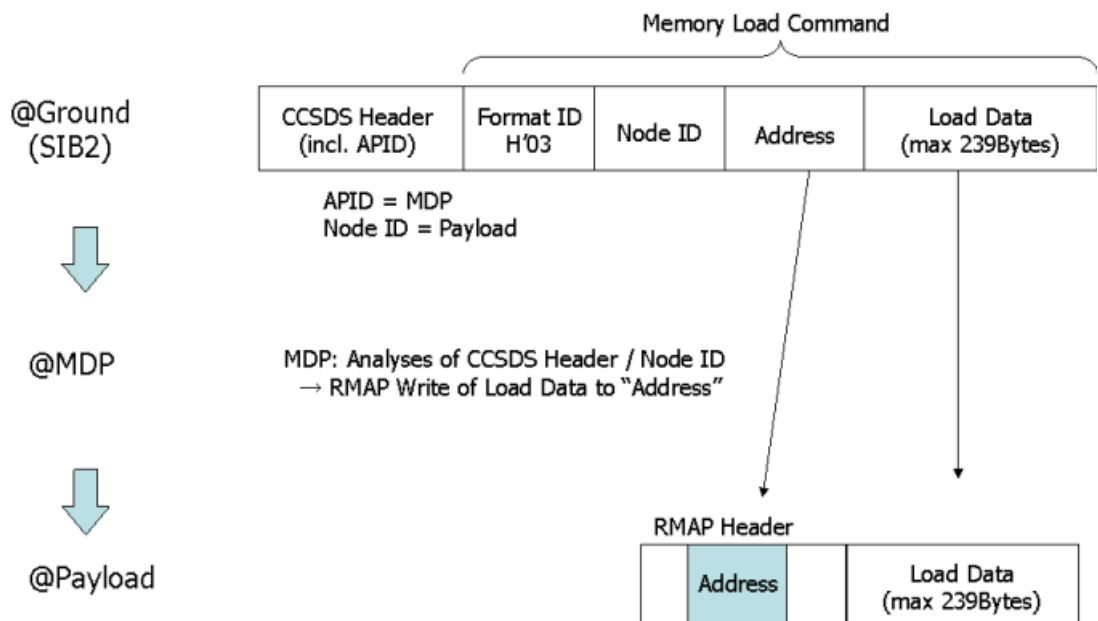

7.0-4 D  
 (3) Memory Dump Format

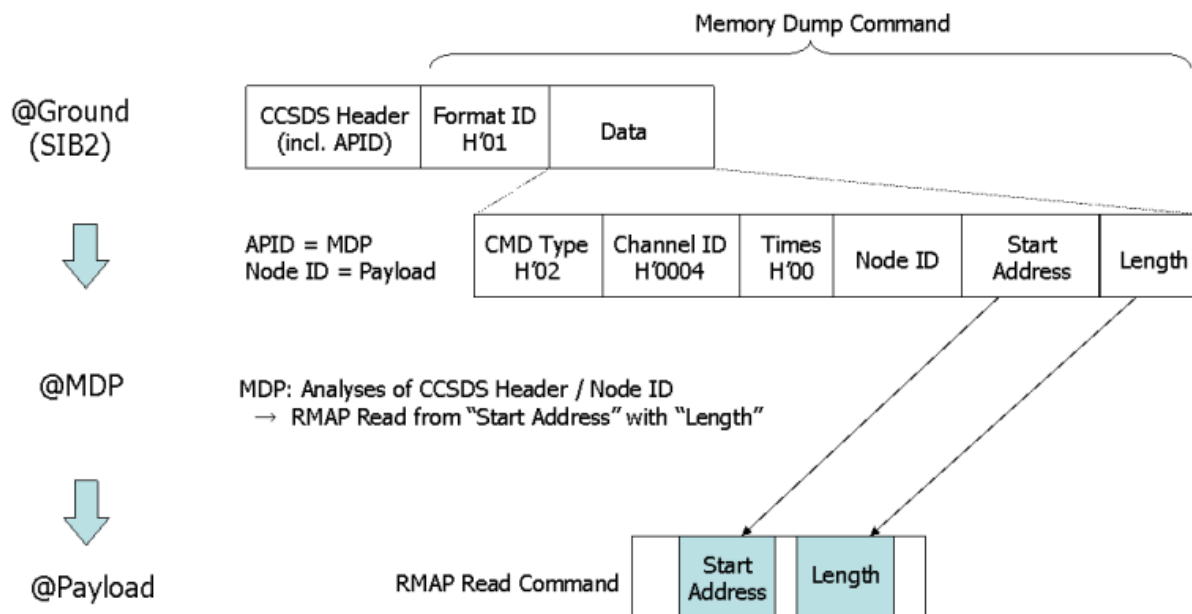

7.0-5 D  
 (4) HK Read Format 及び Mission Data Read Format

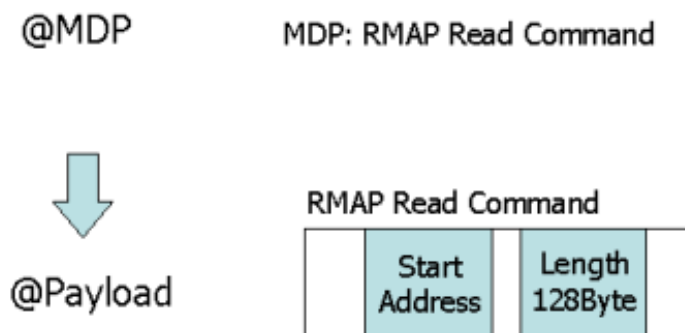

7.0-6 D  
 (5) Sun Pulse 時刻配信 Format

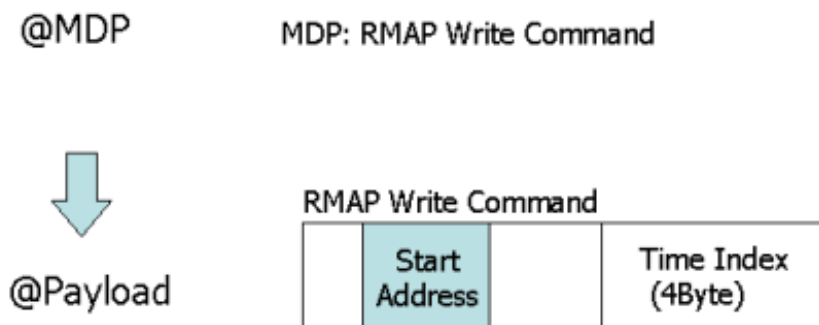

## 8 FM Integration Test

### 8.1 Test Items

#### 8.1.0-1 D

EM および FM 試験において、MDP は、Payload との噛み合わせ試験で、以下の要求が満たされ接続が円滑に行われるかどうか試験する。

In the integration test with the Payload, the MDP will test the following items in order to confirm the fulfilment of the I/F requirement defined in this document:

- |  |   |                       |
|--|---|-----------------------|
| <b>(1) Physical / Signal Layer</b>       |   | <b>(see Sec. 4.1)</b> |
| 4.1.0-2                                  | (Pin assignment)                        |                       |
| 4.1.0-4                                  | (I/F definitions)                       |                       |
| 4.1.0-5                                  | (Harness shield)                        |                       |
| <b>(2) Exchange Layer</b>                |   | <b>(see Sec. 4.2)</b> |
| 4.2.0-1                                  | (Link speed range)                      |                       |
| 4.2.0-2                                  | (Fix of Link speed)                     |                       |
| <b>(3) Packet Layer</b>                  |   | <b>(see Sec. 4.3)</b> |
| 4.3.0-1                                  | (Receipt of RMAP command)               |                       |
| 4.3.0-3                                  | (Reply to RMAP command)                 |                       |
| 4.3.0-5                                  | (Logical address)                       |                       |
| 4.3.0-6                                  | (RMAP Header)                           |                       |
| <b>(4) Endian</b>                        |   | <b>(see Sec. 4.4)</b> |
| 4.4.0-1                                  | (Big endian)                            |                       |
| <b>(5) Command</b>                       |   | <b>(see Sec. 5.1)</b> |
| 5.1.0-2                                  | (Command Buffer)                        |                       |
| 5.1.1.0-2                                | (Timing Requirement)                    |                       |
| 5.1.2.0-2                                | (Command Definition)                    |                       |
| <b>(6) HK data transmission</b>          |   | <b>(see Sec. 5.2)</b> |
| 5.2.0-2                                  | (HK Buffer area)                        |                       |
| 5.2.1.0-2                                | (HK Timing Requirement)                 |                       |
| 5.2.2.0-2                                | (HK Data Format)                        |                       |
| <b>(7) Mission Data transmission</b>     |   | <b>(see Sec. 5.3)</b> |
| 5.3.0-2                                  | (Mission Data Buffer)                   |                       |
| 5.3.1.0-2                                | (Sun Pulse Interval range)              |                       |
| 5.3.1.0-3                                | (Mission Data Timing : Definition)      |                       |
| 5.3.1.0-6                                | (Mission Data Timing: Requirement)      |                       |
| 5.3.2.0-2                                | (Mission Data Format)                   |                       |
| 5.3.2.0-3                                | (Indication of non-effective data)      |                       |
| <b>(8) Memory Load / Dump (if need)</b>  |   | <b>(see Sec. 5.5)</b> |
| 5.5.0-3                                  | (Set up of Direct Memory Access)        |                       |
| 5.5.0-5                                  | (Definition of memory load / dump)      |                       |
| <b>(9) Sun Pulse / Time Distribution</b> |   | <b>(see Sec. 5.6)</b> |
| 5.6.0-6                                  | (Time Distribution / Usage requirement) |                       |
| <b>(10) Memory MAP</b>                   |   | <b>(see Sec. 5.7)</b> |
| 5.7.0-1                                  | (Definition of Address Map)             |                       |
| <b>(11) Safety Mode Transition</b>       |   | <b>(see Sec. 6.1)</b> |
| 6.1.0-1                                  | (Automatic safety mode transition)      |                       |
| 6.1.0-3                                  | (Detection of emergency status)         |                       |



## 8.2 FM Test Schedule

### 8.2.0-1 D

FM test schedule related to DMC - MDP I/F test:

---

<b>(1) TBD (EM: 22-26 Dec 2008)</b>	<b>DMC – MDP I/F test</b>	<b>(2 weeks)</b>
Location:	at ISAS bldg-C	
Objective:	To verify compatibility between DMC and MDP with respect to SpaceWire Link and IP distribution interface. The test#1 will focus test cases on RMAP/SpW protocol levels	
EUT:	DMC(BBM) + DMC-FSW(DHFS release 1) MDP(EM)	
Comment	Payload is not excluded. If it is proposed, we will invite.	
<b>(2) TBD (EM: 11-29 May 2009)</b>	<b>DMC – MDP – Payload I/F test</b>	<b>(4 weeks)</b>
Location	at ISAS bldg-C	
Objectives:	Verification and Demonstrations of AP level communication services incl. Data Recorder (DR) service	
EUT:	DMC(BBM) + DMC-FSW(DHFS release 2) MDP(EM) PI sensors (EM or BBM)	
	<b>[invited dates for each instrument: TBD]</b>	

---

### 8.2.0-2 R

Payload は、遅くとも **TBD (EM: 2009 年 2 月より前)** に、最低一度、MDPとの接続試験を行う。  
 (see Appendix-B8)

At least once, all Payload shall do the I/F integration test with the MDP before **TBD (EM: the end of Feb 2009)**. (see Appendix-B8)

---

*Objectives:	Verification of the items in <b>Sec. 8.1</b> .
*EUT:	MDP (EM or BBM) PI sensors (EM or BBM)
*1 <sup>st</sup> I/F test	Oct. 2008 – Jan 2009
*2 <sup>nd</sup> I/F test	Feb – March 2009

---

### 8.2.0-3 R

Payload は、MDP とのかみ合わせ試験の前に、GSE によって、本稿に示すI/F要求を満たすことを確認しなければならない。

Before the EM and FM integration test with the MDP, Payload shall confirm the fulfilment of the requirements defined in this document by the GSE.

## 9 GSE (MDP Emulator)

### 9.1 Definiton and Function

9.1.0-1 D

The plan for the MDP Simulator distribution:

---

<b>*1<sup>st</sup> Ver.:</b>	<b>March</b>	<b>2008</b>	<b>MGF-O</b>
	<b>April</b>	<b>2008</b>	<b>MPPE/MEA</b>
	<b>May</b>	<b>2008</b>	<b>in Japan</b>
<b>*2<sup>nd</sup> Ver.</b>	<b>June Med</b>	<b>2008</b>	<b>PW/SORBET, PW/MEFISTO</b>
	<b>June 30 – July 1</b>		<b>in Japan (with a meeting)</b> <b>in Europe (with a meeting)</b>

---

9.1.0-2 D

The plan of the function for the MDP Simulator:

---

<b>*1<sup>st</sup> Ver:</b>	<b>Lower layer definition of SpaceWire I/F incl. RMAP protocol</b>	
	<b>(1) Physical / Signal Layer</b>	<b>(see Sec. 4.1)</b>
	<b>(2) Exchange Layer</b>	<b>(see Sec. 4.2)</b>
	<b>(3) Packet Layer</b>	<b>(see Sec. 4.3)</b>
	<b>(4) Endian</b>	<b>(see Sec. 4.4)</b>
<b>*2<sup>nd</sup> Ver:</b>	<b>Higher layer definition implementaed on the RMAP</b>	
	<b>(5) Command</b>	<b>(see Sec. 5.1)</b>
	<b>(6) HK data transmission</b>	<b>(see Sec. 5.2)</b>
	<b>(7) Missional Data transmission</b>	<b>(see Sec. 5.3)</b>
	<b>(8) Memory Load / Dump</b>	<b>(see Sec. 5.5)</b>
	<b>(9) Sun Pulse / Time Distribution</b>	<b>(see Sec. 5.6)</b>
	<b>(10) Memory MAP</b>	<b>(see Sec. 5.7)</b>
	<b>(11) Safety Mode Transition</b>	<b>(see Sec. 6.1)</b>

---

## Appendix-A Contact Point: Engineering Managers

<b>&lt;MDP&gt;</b>	<b>MHI (Japan)</b>	
	Masahiro Taeda (MHI)	masahiro_taeda@mhi.co.jp
	Yasumasa Kasaba (Tohoku Univ.)	kasaba@pat.gp.tohoku.ac.jp
	Takeshi Takashima (JAXA)	ttakeshi@stp.isas.jaxa.jp
<b>[To MDP/DPU1]</b>		
<b>&lt;MGF / MGF-O&gt;</b>	<b>IWF / OeAW (Austria)</b>	
	Olaf Hillenmaier (Magson)	olaf@magson.de
	Markus Wiedemann (Magson)	markus@magson.de
	Werner Mages (OeAW)	Werner.Mages@oeaw.ac.at
<b>&lt;MPPE / MEA&gt;</b>	<b>CESR-CNRS (France)</b>	
	Claude Aoustin (CESR)	claudio.aoustin@cesr.fr
	M.Petiot (CESR)	mathieu.petiot@cesr.fr
<b>&lt;MPPE / MSA , MIA &gt;</b>	<b>Meisei Elec. (Japan)</b>	
	M. Nakazawa (Meisei)	nakazawam@meisei.co.jp
	T. Omoto (Meisei)	omotot@meisei.co.jp
	I. Tanaka (Meisei)	tanakai@meisei.co.jp
	Y. Saito (JAXA)	saito@stp.isas.jaxa.jp
	S. Yokota (JAXA)	yokota@stp.isas.jaxa.jp
<b>&lt;MPPE / ENA&gt;</b>	<b>Meisei Elec. (Japan)</b>	
	Michio Nakazawa (Meisei)	nakazawam@meisei.co.jp
	Asamura Kazushi (JAXA)	asamura@stp.isas.jaxa.jp
<b>&lt;MPPE / HEP-i , HEP-e&gt;</b>	<b>MHI (Japan)</b>	
	K. Genba	kei_genba@mhi.co.jp
<b>[To MDP/DPU2]</b>		
<b>&lt;MGF / MGF-I&gt;</b>	<b>SHI (Japan)</b>	
	Hirofumi Morimoto (SHI)	hrf_morimoto@shi.co.jp
	T. Iwamura (SHI & JAXA)	iwamura@rc4.so-net.ne.jp
	A. Matsuoka (JAXA)	matsuoka@isas.jaxa.jp
<b>&lt;PWI / EWO&gt;</b>	<b>MHI (Japan)</b>	
	Takeshi Miyabara (MHI)	takeshi_miyabara@mhi.co.jp
	Hirotsugu Kojima (Kyoto Univ.)	kojima@rish.kyoto-u.ac.jp
<b>&lt;PWI / SORBET&gt;</b>	<b>Obs. de Paris (France)</b>	
	Moustapha Dekkali (Obs. Paris)	Moustapha.Dekkali@obspm.fr
<b>&lt;PWI / MEFISTO&gt;</b>	<b>KTH / IRF-Uppsalla (Sweden)</b>	
	Lennart Ahlen (IRF-U)	ala@irfu.se
	Lars Bylander (KTH)	lars.bylander@ee.kth.se
	Walter Puccio (IRF-U)	wp@irfu.se
<b>&lt;MSASI&gt;</b>	<b>Meisei Elec. (Japan)</b>	
	T. Watanabe (Meisei)	watanabet@meisei.co.jp
	Shingo Kameda (JAXA)	kameda@perc.it-chiba.ac.jp
<b>&lt;MDM&gt;</b>	<b>Meisei Elec. (Japan)</b>	
	M. NAKAZAWA (Meisei)	nakazawam@meisei.co.jp
	M. Kusakabe (Meisei)	kusakabem@meisei.co.jp
	Y. Tarekado (Meisei)	terakadoy@meisei.co.jp

	M. Fujii (FAM / JAXA)	<a href="mailto:master@famweb.co.jp">master@famweb.co.jp</a>
<MAST/WPT-E>	<b>NIPPI (Japan)</b>	
	T. Sasaki (NIPPI)	<a href="mailto:sasaki_takashi-nippi@nippi.co.jp">sasaki_takashi-nippi@nippi.co.jp</a>
	A. Kumamoto (Tohoku Univ.)	<a href="mailto:kumamoto@pparc.gp.tohoku.ac.jp">kumamoto@pparc.gp.tohoku.ac.jp</a>
	A. Matsuoka (JAXA)	<a href="mailto:matsuoka@isas.jaxa.jp">matsuoka@isas.jaxa.jp</a>

## Appendix-B Data requested to the Payload team

### B-1. Compliance Plan - Format

Item	“OK” or “Planned Configuration”	Reply from MDP
4 Definition of Communication Interface		
4.1 Physical Layer / Signal Layer		
4.1.0-2 (Pin assignment)		
4.1.0-4 (V/F definitions)		
4.1.0-5 (Harness shield)		
4.2 Exchange Layer		
4.2.0-1 (Link speed range)		
4.2.0-2 (Fix of Link speed)		
4.2.0-3 (TimeOut in Init)		
4.2.0-5 (Disconnect Timing)		
4.3 Packet Layer		
4.3.0-1 (Receipt of RMAP CMD)		
4.3.0-3 (Reply to RMAP CMD)		
4.3.0-5 (Logical address)		
4.3.0-6 (RMAP Header)		
4.4 Endian		
4.4.0-1 (Big endian)		
5.1 Command		
5.1.0-2 (Command Buffer)		
5.1.1.0-2 (Timing Requirement)		
5.1.2.0-2 (Command Definition)		
5.2 HK data transmission		
5.2.0-2 (HK Buffer area)		
5.2.1.0-2 (HK Timing)		
5.2.2.0-2 (HK Data Format)		
5.3 Mission Data transmission		
5.3.0-2 (Mission Data Buffer)		
5.3.1.0-2 (Sun Pulse Interval)		
5.3.1.0-3 (Mission Timing Def.)		
5.3.1.0-6 (Mission Timing: Requirement)		

<b>5.3.2.0-2 (Mission Data Format)</b>		
<b>5.3.2.0-3 (Indication of non-effective data)</b>		
5.5 Memory Load / Dump		
<b>5.5.0-3 (Direct Memory Access)</b>		
<b>5.5.0-5 (Def. of MEM load / dump)</b>		
5.6 Sun Pulse / Time Distribution		
<b>5.6.0-6 (Time Distribution / Usage requirement)</b>		
5.7 Memory MAP		
<b>5.7.0-1 (Def. of Address Map)</b>		
6 Interface Error Treatment		
6.1 Safety Mode Transition		
<b>6.1.0-1 (Safety mode transition)</b>		
<b>6.1.0-3 (Detection of emergent)</b>		
8.2 Test Schedule		
<b>8.2.0-2 (Test with MDP)</b>		
<b>8.2.0-3 (Test with GSE)</b>		

**B-2. Address Map : Summary**

(cf. Table 5.1)

Command Buffer (5.1.0-2)		Address	Size	Remark
MDP-DPU1	MEA1	0D80-0D81 [2bytes]	163 B (Fixed)	081222
	MEA2	0D80-0D81 [2bytes]		081222
	MIA	0C00-0C03 [4bytes]		090223
	MSA	0C00-0C05 [6bytes]		090227
	HEP-ele	0C00-0C27 [40bytes]		100123
	HEP-ion	0C00-0C27 [40bytes]		100123
	ENA	0C00-0C1F [32 bytes]		090211
	MGF-O	0C00-0C03 [4 bytes]		090317
MDP-DPU2	MGF-I	0C00-0CA2		081003
	MDM	0C00-0CB4 [163bytes]		090202
	MSASI	0C00-0C03 [4bytes]		090129
	EWO-E	---		---
	EWO-B	0C00-0C42 [66bytes]		090410
	SORBET	0C00-0CA2		080604
	MEFISTO	0080-0117 [152B]		090317
	MAST/WPT-E	0C00-0CA2		081006

HK Buffer (5.2.0-2)		Address to DMC(<=20B) / to MDP(<=108B)	Size	Remark
MDP-DPU1	MEA1	0D00 - 0D13 / 0D14- 0D19	20B / 6B	090608
	MEA2	0D00 - 0D13 / 0D14- 0D19	20B / 6B	090608
	MIA	0D00 - 0D13 / 0D14 - 0D7F	20B / 108B	090223
	MSA	0D00 - 0D13 / 0D14 - 0D7F	20B / 108B	090227
	HEP-ele	0D00 - 0D13 / 0D14 - 0D1F	20B / 12B	090603
	HEP-ion	0D00 - 0D13 / 0D14 - 0D1F	20B / 12B	090603
	ENA	0D00 - 0D13 / 0D14 - 0D7F	20B / 108B	090211
	MGF-O	0D00 - 0D13 / 0D14 - 0D2D	20B / 26B	090323
MDP-DPU2	MGF-I	0D00 - 0D06	7B	100107
	MDM	0D00 - 0D05 / 0D06 - 0D0C	6B / 7B	091228
	MSASI	0D00 - 0D13 / 0D14 - 0D7F	20B / 108B	090129
	EWO-E	---	---	---
	EWO-B	0D00 - 0D13 / 0D14 - 0D7F	20B / 108B	080603
	SORBET	0D00 - 0D13 / 0D14 - 0D7F	20B / 108B	080911
	MEFISTO	0000 - 0013 / 0x014-0x023	20B / 16B	090323
	MAST/WPT-E	0D00 - 0D7F	20B / 108B	081006

TI Register (5.6.0-6)		Address	Size	Remark
MDP-DPU1	MEA1	0F00 - 0F03	4 B (fixed)	081222
	MEA2	0F00 - 0F03		081222
	MIA	0F00 - 0F03		090223
	MSA	0F00 - 0F03		090227
	HEP-ele	0F00 - 0F03		080603
	HEP-ion	0F00 - 0F03		080603
	ENA	0F00 - 0F03		090211
	MGF-O	0F00 - 0F03		080808
MDP-DPU2	MGF-I	0F00 - 0F03		081003
	MDM	0F00 - 0F03		080723
	MSASI	0F00 - 0F03		090129
	EWO-E	0F00 - 0F03		080603
	EWO-B	0F00 - 0F03		080603
	SORBET	0F00 - 0F03		080911
	MEFISTO	N/A (0F00 - 0F03)		090317
	MAST/WPT-E	N/A (0F00 - 0F03)		081006

Mission Data Buffer (5.3.0-2)		Address	Size	Remark
MDP-DPU1	MEA1	0800 – 0C07	1032B	100123
	MEA2	0800 – 0C07	1032B	100123
	MIA	0E00 – 0E03	4B (FIFO)	090223
	MSA	0E00 – 0E03	4B (FIFO)	090227
	HEP-ele	0E00 – 0E01	2B (FIFO)	080603
	HEP-ion	0E00 – 0E01	2B (FIFO)	080603
	ENA	0E00 – 0E03	4B (FIFO)	090211
	MGF-O	0E00 – 0EC9	202 B	090323
MDP-DPU2	MGF-I	0E00 – 0EC9	202 B	081003
	MDM	0E00 – 0E00	1B (FIFO)	090202
	MSASI	0E00 – 0E03	4B (FIFO)	090129
	EWO-E	N/A	N/A	--
	EWO-B	N/A	N/A	--
	SORBET	1000 – 1FFF	4 kB	080911
	MEFISTO	N/A	N/A	--
	MAST/WPT-E	N/A	N/A	--

Memory Load (5.5.0-5)		Address	Size	Remark
MDP-DPU1	MEA1	0600 - 06FF	256B	100123
	MEA2	0600 – 06FF	256B	100123
	MIA	1000 - 21FF	4608B	090223
	MSA	1000 - 21FF	4608B	090227
	HEP-ele	N/A	N/A	080603
	HEP-ion	N/A	N/A	080603
	ENA	N/A	N/A	090211
	MGF-O	N/A	N/A	080808
MDP-DPU2	MGF-I	N/A	N/A	081003
	MDM	N/A	N/A	090202
	MSASI	N/A	N/A	
	EWO-E	2000 – 2FFF 8000 0000 – 800F FFFF	8kB (Register) 1MB (SRAM)	080603
	EWO-B	2000 – 2FFF 8000 0000 – 800F FFFF	8kB (Register) 1MB (SRAM)	080603
	SORBET	N/A	N/A	080911
	MEFISTO	N/A	N/A	090317
	MAST/WPT-E	N/A	N/A	081006

Memory Dump (5.5.0-5)		Address	Size	Remark
MDP-DPU1	MEA1	0E00 - 0EFF	256B	081222
	MEA2	0E00 - 0EFF	256B	081222
	MIA	1000 - 21FF	4608B	090223
	MSA	1000 - 21FF	4608B	090227
	HEP-ele	N/A	N/A	080603
	HEP-ion	N/A	N/A	080603
	ENA	N/A	N/A	090211
	MGF-O	N/A	N/A	080808
MDP-DPU2	MGF-I	N/A	N/A	081003
	MDM	N/A	N/A	090202
	MSASI	N/A	N/A	
	EWO-E	2000 – 2FFF 8000 0000 – 800F FFFF	8kB (Register) 1MB (SRAM)	080603
	EWO-B	2000 – 2FFF 8000 0000 – 800F FFFF	8kB (Register) 1MB (SRAM)	080603
	SORBET	N/A	N/A	080911
	MEFISTO	N/A	N/A	090317
	MAST/WPT-E	N/A	N/A	081006



**B-3. Command Plan: for RMAP Write to the CMD Buffer (cf. 5.1.2.0-2)**

(incl. Safety CMD [cf. 6.1.0-3(1)])

CMD Name	Address & Length	Parameters	Function

(Example of Format)

<i>1</i>	<i>2</i>	<i>3</i>	<i>4</i>	<i>...</i>	<i>239</i>
<i>Address</i>	<i>Param(1)</i>	<i>Param(2)</i>	<i>Param(3)</i>		

**B-4. HK Data Plan: for RMAP Read from the HK Buffer (cf. 5.2.2.0-2)**

HK Name	Address / Bit	Parameters	“to DMC” or “only to MDP”	Meaning

(Ref)                      to DMC    <= 20 bytes    (nominal)  
                                  Total        <= 128 bytes    (nominal)

## B-5. Mission Data Plan: for RMAP Read from Mission Data Buffer

### (1) Definition of Timing (cf. 5.3.1.0-3)

- (1) L : Data size of a mission data packet  
 (2) N : Number of Mission data packet in one sequence  
 (3) V : Link speed  
 (4) T<sub>0</sub> : Interval of the sequence  
 (5) T<sub>1</sub> : Shortest interval of mission data packet

$$\begin{aligned} \text{(Ref) Averaged Data Rate to the MDP} & (N \times L) / T_0 \\ \text{Data Buffer prepared in the MDP} & [(N \times L) / T_0] \times 120 \text{ sec} \end{aligned}$$

Table B5-A : Current Plan for Payload Mission data accumulation .

Payload		Sequence Interval T <sub>0</sub>	Num. N	Pac Size /Read L	Interval T <sub>1</sub>	Incr/ No-Incr	Remark	
MDP-DPU1	MEA1	2.000	18	1032B	111ms	Incr	V=1.6MHz	
	MEA2	2.000	18	1032B	111ms	Incr	V=1.6MHz	
	MIA	4.000	25	5260B	125ms	No-Incr	V=3.2MHz	
	MSA	1.000	34	1024B	25ms	No-Incr	V=3.2MHz	
	HEP-ele	4.000	34	420B	117ms	No-Incr (FIFO)	V=1.6MHz	
	HEP-ion	1.000	34	2016B	29ms	No-Incr (FIFO)	V=1.6MHz	
	ENA	4.000	16	3072B	250msec	No-Incr (FIFO)	V=1.6MHz	
	MGF-O	1.000	9	202	110ms	Incr	V=1.6MHz	
MDP-DPU2	MGF-I	1.000	9	202	110ms	Incr	V=1.6MHz	
	MDM	60.000	1	120B	N/A	No-Incr (FIFO)	V=1.6MHz	
	MSASI	4.000	32	6528B	125msec	No-Incr (FIFO)	V=3.2MHz	
	EWO-E	(RMAP Write)						V=4.1MHz
	EWO-B	(RMAP Write)						V=4.1MHz
	SORBET	4.000	1	4 kB	N/A	Incr	V=1.6MHz	
	MEFISTO	(no TLM data)						V=1.6MHz
	MAST/WPT-E	(no TLM data)						V=1.6MHz

### (2) Mission Data Format (cf. 5.3.2.0-2, 5.3.3.0-2, 5.3.2.0-3, 5.6.0-6)

Address	Bytes	Bit	Parameters	Contents
	4 bytes	--	0x00000000-FFFFFFFF	T <sub>0</sub> (T <sub>I</sub> at Sun pulse)
	2 bytes	--	0x0000 – FFFF	T <sub>1</sub> (time from the sun pulse)

\* Definition of "Non-effective data"

\* Definition of Timing Data

## B-6. Memory Load / Dump Definition (cf. 5.5.0-5)

Address	Bytes	Contents	Usage (inc. When / Frequency)

## B-7. Safety Mode

-Not applicable

\*MGF-O

\*MGF-I

\*SORBET

\*EWO(/AM2P)

**(1) Definition of Safety mode**

**(cf. 6.1.0-1)**

**(2) Definition of Safety-transition CMD**

**(cf. 6.1.0-3)**

**(3) Detection method of the Emergency**

**(cf. 6.1.0-3)**

## B-8. EM Test Plan

### Verification Plan at the MDP – Payload I/F Test

\* Payload should make test as much as possible by the GSE at each institute.

No	Item	Contents	Method	Request to Payload
0	Ground Check	-Grounding of Inner shield to COM(2) (4.1.0-6)	- Conduction between Inner-shield & COM2 at the Payload connector pin.  <Test equipment prepared by the MDP team> - Tester	* Confirmation of Grounding
1	FIT CHECK & SpW-LINK CHECK	-Fit check / Pin assignment / voltage check (4.1.0-2, 4.2.0-1) -Ground connection check (4.1.0-6) -Interface (eg. Voltage) check (4.1.0-4) -Link speed range (4.2.0-1, 4.2.0-2)	- Connection between MDP & Payload - Check the wave form on the harness by an Oscilloscope.  <Test equipment prepared at ISAS> - Oscilloscope - BOB - SpW Analyzer	* Confirmation of Harness definition * Definition of Link speed range "from Payload to MDP"
2	PACKET LAYER CHECK #1 (TimeCode)	-Receipt of TimeCode. (4.3.0-1)	- Send the single / multiple TimeCode from MDP to Payload  <Test equipment prepared at ISAS > - SpW Analyzer	* Confirmation of the receipt of TimeCode
3	PACKET LAYER CHECK #2 (RMAP Write Command)	-Receipt of RMAP Write Command (4.3.0-1) -Send of RMAP Write Reply within 63msec (4.3.0-3, 5.1.1.0-2) -Adaption of the defined RMAP Header (4.3.0-5, 4.3.0-6) -Adaption of BIG-Endian (4.4.0-1) -Check of MEMORY LOAD to planned address range (5.5.0-3)	- Send the single / multiple RMAP Write Command from MDP to Payload - Check the RMAP Write Reply packet by MDP - Measurement of the interval between Write & WriteReply packets by SpW Analyser  <Test equipment prepared at ISAS > - SpW Analyzer - DMC Simulator (from NEC) - Memory-Load Program	* Definiton of Address Area for Command Buffer TI resgiter Memory load (if it is needed) * Confirmation of Memory write

4	PACKET LAYER CHECK #3 (RMAP Read Command)	<ul style="list-style-type: none"> <li>-Receipt of RMAP Read Command (4.3.0-1)</li> <li>-Send of RMAP Read Reply within 63msec (4.3.0-3, 5.2.1.0-2)</li> <li>-Adaption of the defined RMAP Header (4.3.0-5, 4.3.0-6)</li> <li>-Adaption of BIG-Endian (4.4.0-1)</li> <li>-Check of MEMORY READ from planned address range (5.5.0-3)</li> </ul>	<ul style="list-style-type: none"> <li>- Send the single / multiple RMAP Read Command from MDP to Payload</li> <li>- Check the RMAP Read Reply packet by MDP</li> <li>- Measurement of the interval between Read &amp; ReadReply packets by SpW Analyser</li> </ul> <p>&lt;Test equipment prepared at ISAS &gt;</p> <ul style="list-style-type: none"> <li>- SpW Analyzer</li> <li>- DMC Simulator (from NEC)</li> </ul>	<ul style="list-style-type: none"> <li>* Definiton of Address Area for HK Buffer</li> <li>Mission Data Buffer</li> <li>Memory dump (if it is needed)</li> <li>* Confirmation of Memory read</li> </ul>
5	Command	<ul style="list-style-type: none"> <li>-Receipt (&amp; execution) of All Commands (5.1.0-2, 5.1.1.0-2, 5.1.2.0-2)</li> </ul>	<ul style="list-style-type: none"> <li>- Send the Commands from MDP (non-CCSDS)</li> <li>- Send the Commands from DMC (CCSDS)</li> </ul> <p>&lt;Test equipment prepared at ISAS &gt;</p> <ul style="list-style-type: none"> <li>- SpW Analyzer</li> <li>- DMC Simulator (from NEC)</li> </ul>	<ul style="list-style-type: none"> <li>* Definition of All Commands (Registration of All Commands to System-level GSE at the DMC test)</li> <li>* Confirmation of Command receipt</li> </ul>
6	HK Read	<ul style="list-style-type: none"> <li>-Get the HK data with 1-sec interval (5.2.0-2, 5.2.1.0-2, 5.2.2.0-2)</li> </ul>	<ul style="list-style-type: none"> <li>- Set the HK Accumulation Sequence (1 sec interval) to the MDP</li> <li>- Check the HK data by GSE through MDP / DMC (or those emulators)</li> </ul> <p>&lt;Test equipment prepared at ISAS &gt;</p> <ul style="list-style-type: none"> <li>- SpW Analyzer</li> <li>- DMC Simulator (from NEC)</li> </ul>	<ul style="list-style-type: none"> <li>* Definition of HK Data</li> <li>* Preparation of HK Check Tool from the telemetry</li> </ul>
7	Mission Data Read [only the payloads with Mission Data output]	<ul style="list-style-type: none"> <li>-Get the Mission data with defined sequence &amp; intervals (5.3.0-2, 5.3.1.0-2, 5.3.1.0-3, 5.3.1.0-6, 5.3.2.0-2, 5.3.2.0-3, 5.6.0-6)</li> </ul>	<ul style="list-style-type: none"> <li>- Set the Mission Data Accumulation Sequence to the MDP. (Zitter can be changed by MDP-emulator GSE.)</li> <li>- Check the Mission data by GSE through MDP / DMC (or those emulators)</li> </ul> <p>&lt;Test equipment prepared at ISAS &gt;</p> <ul style="list-style-type: none"> <li>- SpW Analyzer</li> <li>- DMC Simulator</li> </ul> <p>Mission data can only be kept intermittently. Long &amp; continuous telemetry can not be taken by this test.</p>	<ul style="list-style-type: none"> <li>* Definition of Timing for Mission Data</li> <li>* Definiton of Mission Data</li> <li>* Preparation of Data Check Tool from the telemetry</li> </ul>

8	Time Distribution	- Check the Time Distribution (5.6.0-6)	- Send the Sun Pulse & TI from MDP <Test equipment prepared at ISAS > - SpW Analyzer - DMC Simulator (from NEC)	* Definition of proper timing treatment in the Payload * Confirmation of TI receipt
9	Emulated Operation	- Emulation of some realistic operations - Change of Sun Pulse Timing in 4.0 - 5.5 sec	- Simultaneous Execution of Test-5/6/7/8 - With variation of Sun Pulse Timing <Test equipment prepared at ISAS > - SpW Analyzer - DMC Simulator	* Check whole packets * Preparation of HK&Data Check Tool
10	Safety Mode [only the payloads with Safety Mode]	- Cut the SpW Link between MDP & Payload, and check the transition to Safety Mode (6.1.0-1, 6.1.0-3)	- Link Disable of MDP SpW I/F during 16 sec. <Test equipment prepared at ISAS > - SpW Analyzer - DMC Simulator (from NEC)	* Definition & Set up of the Safety Mode * Confirmation of the transition to the Safety Mode

No	Item	Contents	Method	Request to Payload
0	Ground Check	- Payload 側基板にて、Inner shield-COM(2)が接地されていること (4.1.0-6)	- テスターを用い、Payload 側コネクタピンにて、Inner shield と COM(2)間の抵抗値を測定。  <MDP Team の準備> - Tester	* "接地"判定基準の提示
1	FIT CHECK & SpW-LINK CHECK	SpW 通信波形を計測し、以下を検証する。 (1) 電圧値が範囲内であること (4.1.0-2) (4.1.0-4) (2) タイミングが正しいこと (4.1.0-2) (4.2.0-1) (3) 初期リンクが張れること (4.2.0-1) (4) 初期/通常リンク時で速度が変わらないこと (4.2.0-2)	(1) (2) SpW Analyser を接続し、Payload からの出力波形をオシロスコープにて測定。 (3) (4) MDP-Payload を接続し、SpW Analyser にてリンク速度を測定。  <MDP Team の準備> - Oscilloscope - BOB - SpW Analyzer	* ハーネス定義の確認 * Payload→MDP の SpW リンク速度範囲の提示
2	PACKET LAYER CHECK #1 (TimeCode)	MDP から TimeCode を送信し、以下を検証する。 ・ Payload が TimeCode を正しく受信すること。(4.3.0-1)	- MDP から単発/複数の TimeCode を送信する。  <MDP Team の準備> - SpW Analyzer	* TimeCode が正しく受信できたことの確認
3	PACKET LAYER CHECK #2 (RMAP Write Command)	MDP から RMAP Write Command を送信し、以下を検証する。 ・ RMAP Write Command を受信すること (4.3.0-1) ・ Payload が 63ms 以内に RMAP Write Reply を返すこと (4.3.0-3) (5.1.1.0-2) ・ Payload は、IRD 記載の RMAP Header を受信できること (4.3.0-5, 4.3.0-6) ・ ビッグエンディアンでデータ送受信できること (4.4.0-1) ・ メモリロード可能のこと (5.5.0-3)	MDP から単発/複数の RMAP Write Command を送信し、RMAP Write Reply 受信をチェックする。 (Command, 時刻配信, メモリロードの3パターンを実施) SpW Analyser にて Write-WriteReply 間の時間を測定  <MDP Team の準備> - SpW Analyzer - DMC Simulator (from NEC) - Memory-Load Program	* 以下のアドレスエリアの定義 Command Buffer TI resgiter Memory load (必要な場合) * RMAP Write Command が正しく受信出来たことの確認。

4	PACKET LAYER CHECK #3 (RMAP Read Command)	MDP から RMAP Read Command を送信し、以下を検証する。 ・ RMAP Read Command を受信すること (4.3.0-1) ・ Payload が 63ms 以内に RMAP Read Reply を返すこと (4.3.0-3) (5.2.1.0-2) ・ Payload は、IRD 記載の RMAP Header を受信できること (4.3.0-5, 4.3.0-6) ・ ビッグエンディアンでデータ送受信できること (4.4.0-1) ・ メモリダンプ可能のこと (5.5.0-5)	MDP から単発/複数の RMAP Read Command を送信し、RMAP Read Reply 受信をチェックする。 (HK Read, MissionData Read, メモリダンプの 3 パターンを実施) ・ SpW Analyser にて Write-WriteReply 間の時間を測定 (5.2.1.0-2)  <MDP Team の準備> - SpW Analyzer - DMC Simulator (from NEC)	* 以下のアドレスエリアの定義 HK Buffer Mission Data Buffer Memory dump (必要な場合) * RMAP Read に対する Reply パケットが正しいことの確認。
5	Command	MDP から Payload にコマンドを送信し、以下を検証する。 ・ 全コマンドが正しく送信できること。 (5.1.0-2, 5.1.1.0-2, 5.1.2.0-2)	- MDP から non-CCSDS 形式でコマンドを送信する - DMC Simulator から CCSDS 形式でコマンドを送信する (CCSDS)  <MDP Team の準備> - SpW Analyzer - DMC Simulator (from NEC)	* 全コマンドリストの準備 (SIB2 への登録できるもの)。 * コマンド受信できたことの確認。チェックツールの用意。
6	HK Read	MDP から Payload に HK Read を行い、以下を検証する。 ・ 正しく HK 取得できること。 (5.2.0-2, 5.2.1.0-2, 5.2.2.0-2)	- MDP から定期的 (1sec 間隔) に HK 収集 - GSE にて HK を表示し、内容を確認  <MDP Team の準備> - SpW Analyzer - DMC Simulator (from NEC)	* HK Data の定義 * HK の整合性の確認。チェックツールの用意。
7	Mission Data Read [only the payloads with Mission Data output]	MDP から Payload に MissionData Read を行い、以下を検証する。 ・ 正しくミッションデータを取得できること。 (5.3.0-2, 5.3.1.0-2, 5.3.1.0-3, 5.3.1.0-6, 5.3.2.0-2, 5.3.2.0-3, 5.6.0-6)	- MDP から定期的にミッションデータ収集する。 (Zitter は MDP-emulator GSE で変更可能) - 収集終了時に、GSE にて取得したミッションデータを表示し確認。  <MDP Team の準備> - SpW Analyzer - DMC Simulator Mission data は、間歇的にのみ出力される。 長時間連続テレメトリはこの試験では取得できない	* ミッションデータ収集タイミングの提示。 * ミッションデータの定義 * ミッションデータの整合性の確認。 (ミッションデータ確認用ツールの準備)



8	Time Distribution	MDP から Payload に時刻配信を行い、以下を検証する。 ・ 正しく時刻通知ができること (5.6.0-6)	- MDP から Sun Pulse 及び衛星時刻を送信する。 <MDP Team の準備> - SpW Analyzer - DMC Simulator (from NEC)	* 適切なタイミング情報取り扱いの定義 * TI 受信の確認
9	Emulated Operation	実運用模擬。 Sun Pulse Timing を 4.0 - 5.5 sec 変更し、実運用模擬。 (5.3.1.0-2)	- 5, 6, 7, 8 を同時に実施する。 - Sun Pulse Timinng を変更して 5, 6, 7, 8 を実施。 <MDP Team の準備> - SpW Analyzer - DMC Simulator	- 検証したい Sun Pulse Timing を提示。 - ミッションデータが危険な状態にならないことを確認する。(HK 確認用ツールの準備) (ミッションデータ確認用ツールの準備)
10	Safety Mode [only the payloads with Safety Mode]	MDP と Payload との SpW リンクを切断し、以下を検証する。 ・ Payload が Safety Mode に移行すること (6.1.0-1, 6.1.0-3)	・ MDP-Payload の SpaceWire I/F を 16sec 間、 リンク Disable 状態にする。 <MDP Team の準備> - SpW Analyzer - DMC Simulator (from NEC)	* Safety Mode の定義・実装 * Safety Mode 移行の確認。

## B-9. Format to/from PI tasks in MDP

### (1) MDP Command: for Data Dump

To MDP/DPU1	MD1I*	MPPE, MGF-O
To MDP/DPU2	MD2I*	MGF-I, MDM, MSASI, PWI, MWE

#### <Initialize>

<b>MD?U_INIT</b>	<b>MDP User Task: All initialize</b>		
<b>MD?U_ERRCLR</b>	<b>MDP User Task: Error Clear</b>		
<b>MD?U_JPEG_SET (B1)</b>	<b>MDP User Task: JPEG Table Set</b>	<b>B1: Table</b>	<b>0x00-0x02</b>

#### <User-HK production>

<b>MD?U_HK_STRT</b>	<b>User-HK : Continuous repro - Sequence Stop</b>		
<b>MD?U_HK_STOP</b>	<b>User-HK : Continuous repro - Sequence Stop</b>		
<b>MD?U_HK_SET (B1) (B2)</b>	<b>User-HK : Continuous repro - Interval Set</b>		
	<b>B1</b>	<b>Node-ID</b>	<b>0x03-0x14</b> <b>0xFF:all</b>
	<b>B2</b>	<b>b4-7</b>	<b>SW-Status</b> <b>0:DIS</b> <b>1:ENA</b>
		<b>b0-3</b>	<b>Interval: 2^X (sec)</b> <b>0x0(1s)-0xE(18h)</b>
<b>MD?U_HK_ONESHOT (B1)</b>	<b>User-HK: OneShot</b>	<b>B1</b>	<b>Node-ID</b> <b>0x03-0x14</b>

#### <Data collection >

<b>MD?U_BUF_CLCT (B1)(B2)</b>	<b>Collection ENA/DIS</b>	<b>B1</b>	<b>node-ID</b>	<b>0x05-0x12</b>	<b>0xFF:all</b>
		<b>B2</b>	<b>Collection</b>	<b>0:1DIS</b>	<b>1: ENA</b>
<b>MD?U_BUF_OVW (B1)(B2)</b>	<b>OverWrite ENA/DIS</b>	<b>B1</b>	<b>node-ID</b>	<b>0x05-0x12</b>	<b>0xFF:all</b>
		<b>B2</b>	<b>b4-7</b>	<b>0: LONG</b>	<b>1: SHORT</b> <b>0xF: both</b>
			<b>B0-3</b>	<b>0: DIS</b>	<b>1: ENA</b>
			<b>Collection</b>	<b>1:ENA 0:DIS</b>	
<b>MD?U_BUF_LONG (B1)</b>	<b>LONG buffer</b>	<b>B1</b>	<b>node-ID</b>	<b>0x05-0x12</b>	
<b>MD?U_BUF_SHORT (B1)</b>	<b>SHORT buffer</b>	<b>B1</b>	<b>node-ID</b>	<b>0x05-0x12</b>	
				<b>0xFF:all (except ENA, MDM, MSASI, SOR)</b>	
<b>MD?U_BUF_CLCT_MSAS (B1)</b>	<b>MSASI Collect Start</b>	<b>B1</b>	<b>Num of Spin before the COLLECT-STOP</b>		

#### <TLM production >

<b>MD?U_TLM_CMP (B1)(B2)(B3)</b>	<b>L&amp;M&amp;H Compression Mode set</b>			
	<b>B1</b>	<b>Node-ID</b>	<b>0x03-0x14</b>	<b>0xFF: ALL</b>
	<b>B2</b>	<b>Data-ID</b>	<b>EWO:0x0-0x3</b>	<b>Others:0</b>
	<b>B3</b>	<b>b4-7</b>	<b>H</b>	<b>0: non</b> <b>1:JPEG-rev</b>
				<b>2:JPEG-nonrev</b> <b>3:thers&gt;User-def</b>
		<b>B0-3</b>	<b>L&amp;M</b>	<b>0: non</b> <b>1:JPEG-rev</b>
				<b>2:JPEG-nonrev</b> <b>3:User-def</b>
<b>MD?U_TLM_LM_STRT</b>	<b>L&amp;M Repro Start</b>			
<b>MD?U_TLM_LM_STOP</b>	<b>L&amp;M Repro Stop</b>			

<b>MD?U_TLM_H_DUMP (B1)(B2)(B3) (B4) (B5) (B6) (B7) (B8) (B9)</b>		<b>H DUMP</b>	
<b>B1</b>	<b>Node-ID</b>	<b>0x03-0x14</b> (except ENA, MDM, MSASI, SOR) <b>0xFF: ALL</b> (except ENA, MDM, MSASI, SOR) <b>0xEE: STOP!</b>	
<b>B2</b>	<b>Data-ID</b>	<b>EWO:0x0-0x3</b>	<b>Others:0</b>
<b>B3</b>	<b>DR-ID</b>	<b>0: H-0 (CAL)</b> (AM2P: only 0)	<b>1-5: H1-5 (sync)</b>
<b>B4-7</b>	<b>TI-Start(MSB-&gt;LSB)</b>		<b>(lsb: 31.25ms)</b>
		<b>00000000</b> Oldest	
		<b>FFFFFFFF</b> Newest	
<b>B8-9</b>	<b>TI-Length (MSB-&gt;LSB)</b>	<b>lsb: 31.25ms</b>	<b>Max: 0xFFFE = 34min</b>
		<b>0000</b>	<b>1 packet only</b>
		<b>0001</b>	<b>1 block only</b>
		<b>FFFF</b>	<b>All</b>

---

---

---

<SAMPLE CMD Sequence — for MDP1 — HEP-E (Node-ID: 0x09)>

\*\*\* Set up of DMC / MDP / HEP-E \*\*\*

0100 .# \*\*\* User-HK Dump: Once \*\*\*

0101 . MD1U\_HK\_ONESHOT 0x09

0110 .# \*\*\*User-HK Rep: Continuous - Once per 2sec \*\*\*

0111 . MD1U\_HK\_SET 0x09 0x01

0113 . MD1U\_HK\_STRT

0115 . MD1U\_HK\_STOP

0120 .# \*\*\* TLM H data dump \*\*\*

0121 .# Data collecton start: (0x09=HEP-E, 0xFF=Start)

0122 . MD1F\_DPU\_MIS\_CLCT 0x09 0xFF  
(MD1U\_BUF\_CLCT 0x09 0x01)

0124 .# Data collecton stop: (0x09=HEP-E, 0x00=Stop) [1 Block later]

0125 . MD1F\_DPU\_MIS\_CLCT 0x09 0x00  
(MD1U\_BUF\_CLCT 0x09 0x00)

0126 .#

0127 .# TLM H Dump: Head 1 packet of the newest Block

0128 .# [0x09=HEP-E, 0x00=Data-ID, 0x00=Dr-ID, 0xFFFFFFFF=Newest 0x0000:1-packet]

0129 . MD1U\_DS\_DUMP\_PAC 0x09 0x00 0x00 0x01  
MD1U\_TLM\_H\_DUMP 0x09 0x00 0x00 0xFFFFFFFF 0x0000

0140 .# \*\*\* TLM L&M data rep \*\*\*

0141 .# Data collecton start: (0x09=HEP-E, 0xFF=Start)

0142 . MD1F\_DPU\_MIS\_CLCT 0x09 0xFF  
(MD1U\_BUF\_CLCT 0x09 0x01)

0143 .

0148 .# TLM data REP start/stop

0149 .MD1U\_TLM\_LM\_STRT

0150 .

0152 .MD1U\_TLM\_LM\_STOP

0160 .

0161 .# Data collecton stop: (0x09=HEP-E, 0x00=Stop) [1 Block later]

0162 . MD1F\_DPU\_MIS\_CLCT 0x09 0x00  
(MD1U\_BUF\_CLCT 0x09 0x00)

---

---

\*Caution: For instruments under DPU2

MD1F > MD2F

MD1U > MD2U

**(2) MDP Telemetry for Data Dump**

<Restriction for FM : DMC-MDP IF>

Data flow                   <= 4 packet / 125msec                   for each DPU  
 Packet size                <= 1042byte                         for both DPU

**A. Format**

[CCSDS-Primary (6B)] [CCSDS-Secondary (7B) + blank(1B)] [Common EM-Header (10B)] [Comment] [Data]

**[CCSDS Primary] (6B)**

TM Packet Primary Header (6 bytes)							Secondary Header 7 (or 12) bytes
Version	Type	Sec.Header Flag	Application Process ID	Sequence Flag	Sequence Count	Packet Length	
3 bits	1 bit	1 bit	11 bits	2 bits	14 bits	16 bits	
0	0	1	(see table)	11	[increment]	2 <sup>nd</sup> -head(8) + EM-head(10) + Data	

**[CCSDS: Secondary] (Non-division case : 7B) + "blank:1B"**

TM Packet Secondary Header (ADU Header) : 7bytes				
Time	Category	Packet Identifier	Packet Sequence Flag	ADU Count
(32 bits)	(8bits)	(8bits)	for each ADU	( 6bits)
LSB:31.25ms	(see table)	[TBD]	(2bits)	[increment]
			11 [non-segmented]	

**\*Packet ID: Free Use by User-TASK**

**[Common FM-Header] (10B)**

<b>NodeID/Data-ID</b>	<b>Mode-ID</b>	<b>*TI-Data</b>	<b>Counter</b>	<b>Size-Comment</b>	<b>Size-Data</b>
1B	1B	4B (MSB>LSB)	1B	1B	2B (MSB>LSB)

b3-7: NodeID	b4-7 CompMode	(Free Use)	(Free Use)	(Free Use)
b0-2: DataID	00: non			
	01: JPEG-rev			
	10: JPEG-nonrev			
	11: UserDef			
	b0-3 DataContent			
	0:HK	1:OneShot		
	2:L	3:M		
	4:H-0 (CAL etc.)			
	5-9: H-1~5 (Sync-Trigger)			

[Comment]                   in "Size-Comment"                   (MAX: 128B)

[Data]                        in "Size-Data"                       (MAX: 0x2000)                       [This size is 'before JPEG Compression' ]

**<Example: DMC Output in EM>**

0E 19 00 00 03 F9 00 00 A6 F8 20 FF 00 00 18 00	CCSDS-Primary (6B)	0x0E19: APID (DPU1-U HK)
00 0A 6F 83 00 00 03 E8 1B 02 00 00 06 32 01 00	CCSDS-Secondary (7+1B)	20: Category (DPU1-U HK)
02 00 7F AE 00 00 23 00 00 0A 6D C4 00 00 00 00	FM-Header (10B)	0x18: NodeID/DataID (DPU1)
00 00 00 00 00 00 00 FF 00 00 00 00 FF 00 00 00	Data (1000B)	0x03E8: Data size = 1000B

.....

(3) APID, Node-ID, Data-ID, and Category-ID> (from MMO-MDP-DMCCR [JX-MMO-MDP-0004])

	NodeID (5bit)+ DataID(3bit)	Node ID	Data ID	User-HK		One-Shot		Mission-TLM			
				APID	Cat-ID	APID	Cat-ID	APID	Cat-ID:L	Cat-ID:M	Cat-ID:H
DPU1	0x19	0x03	0	0x619	32 (0x20)	(HK)	41 (0x29)	0x519	50 (0x32)	60 (0x3C)	70/80/90/100/110/120 (0x46/50/5A/64/6E/78)
DPU2	0x21	0x04	0	0x621		(HK)		0x521			
MPPE/MEA1	0x28	0x05	0	0x628	33 (0x21)	(HK)	42 (0x2A)	0x528	51 (0x33)	61 (0x3D)	71/81/91/101/111/121 (0x47/51/5B/65/6F/79)
MPPE/MEA2	0x30	0x06	0	0x630		(HK)		0x530			
MPPE/MIA	0x38	0x07	0	0x638		(HK)		0x538			
MPPE/MSA	0x40	0x08	0	0x640		(HK)		0x540			
MPPE/HEP-e	0x48	0x09	0	0x648	34 (0x22)	(HK)		0x548	52 (0x34)	62 (0x3E)	72/82/92/102/112/122 (0x48/52/5C/66/70/7A)
MPPE/HEP-i	0x50	0x0A	0	0x650		(HK)		0x550			
MPPE/ENA	0x58	0x0B	0	0x658	35 (0x23)	(HK)		0x558	44 (0x2C)		
MGF-O	0x60	0x0C	0	0x660	36 (0x24)	(HK)		0x560	53 (0x35)	63 (0x3F)	73/83/93/103/113/123 (0x49/53/5D/67/71/7B)
MGF-I	0x68	0x0D	0	0x668		(HK)		0x568	54 (0x36)	64 (0x40)	74/84/94/104/114/124 (0x4A/54/5E/68/72/7C)
MDM	0x70	0x0E	0	0x670	37 (0x25)	(HK)		0x570	45 (0x2D)		
MSASI	0x78	0x0F	0	0x678	38 (0x26)	(HK)		0x578	46(A) (0x2E)	47(B) (0x2F)	
PWI/EWO-WFCE	0x80	0x10	0	0x680	39 (0x27)	(HK)		0x580	55 (0x37)	65 (0x41)	75/85/95/105/115/125 (0x4B/55/5F/69/73/7D)
PWI/EWO-WFCB	0x83		3								76/86/96/106/116/126 (0x4C/56/60/6A/74/7E)
PWI/EWO-EFD	0x82		2								77/87/97/107/117/127 (0x4D/57/61/6B/75/7F)
PWI/EWO-AM <sup>2</sup> P	0x81		1								78 (0x4E)
PWI/SORBET	0x90	0x12	0	0x690	40 (0x28)	(HK)		0x590	59 (0x3B)	69 (0x45)	
PWI/MEFISTO	0x98	0x13	--	0x698		(HK)					
PWI/MWE (ext.)	0xA0	0x14	--	0x6A0	40 (0x28)	(HK)		--	--	--	--

(4) SDRAM Assignment

	Long Buffer			Short Buffer			Node ID	Dat ID	SDRAM Design Parameters: Block Definition					
	Num Block	Len. [sec]	Len. [kB]	Num Block	Len. [sec]	Len. [kB]			Rate [B/s]	Rate [B/spin]	Block Int. [sec]	Block Size [Bytes]	Pac / Blc	Packet size in SDRAM [Bytes]
MDP/DPU1	---	---	---	---	---	---	0x03	0	---		---	---	---	---
MDP/DPU2	---	---	---	---	---	---	0x04	0	---		---	---	---	---
MPPE/MEA1	600	1200	11405	8	16	152	0x05	0	9504	38016	2	19008	18	(12+ 1032 + 1 + 11) 1056
MPPE/MEA2	600	1200	11405	8	16	152	0x06	0	9504	38016	2	19008	18	(12+ 1032 + 1 + 11) 1056
MPPE/MIA	300	1200	39600	4	16	528	0x07	0	33000	132000	4	132000	25	(12+ 5260 + 1 + 7) 5280
MPPE/MSA	1200	1200	42432	16	16	566	0x08	0	35360	141440	1	35360	34	(12+ 1024 + 1 + 3) 1040
MPPE/HEP-e	300	1200	4570	4	16	61	0x09	0	3808	15232	4	15232	34	(12+ 420 + 1 + 15) 448
MPPE/HEP-i	1200	1200	82906	16	16	1105	0x0A	0	69088	276352	1	69088	34	(12+ 2016 + 1 + 3) 2032
MPPE/ENA	300	1200	14822	3	N/A	148	0x0B	0	12352	49408	4	49408	16	(12+ 3072 + 1 + 3) 3088
MGF-O	1200	1200	2419	16	16	32	0x0C	0	2016	8064	1	2016	9	(12+ 202 + 1 + 9) 224
<b>DPU1 - TOTAL</b>	<b>5430</b> <b>(tot:5505)</b>		<b>209MB</b> <b>(tot:213MB)</b>	<b>75</b>		<b>2.7MB</b>			<b>174632</b> <b>(175kB/s)</b>					
MGF-I	1200	1200	2419	16	16	32	0x0D	0	2016	8064	1	2016	9	(12+ 202 + 1 + 9) 224
MDM	10	600	1.44	3	N/A	0.4	0x0E	0	2.4	9.6	60	144	1	(12+ 120 + 1 + 11) 144
MSASI	117	468	24501	3	N/A	628	0x0F	0	52352	209408	4	209408	32	(12+ 6528 + 1 + 3) 6544
PWI/EWO-WFCE	60	240	79782	4	16	5325	0x10	0	266240	1064960	4(-5)	1331200	640	(16+ 2058 + 1 + 5) 2080
PWI/EWO-AM2P	3	12	3994	3	N/A	3994		1	266240	1064960	4(-5)	1331200	640	(16+ 2058 + 1 + 5) 2080
PWI/EWO-EFD	300	1200	1555	4	16	21		2	1036.8	4147.2	4(-5)	5184	2	(16+ 2570 + 1 + 5) 2592
PWI/EWO-WFCB	60	240	119194	4	16	7946		3	397312	1589248	4(-5)	1986560	640	(16+ 3082 + 1 + 5) 3104
PWI/SORBET	300	1200	1234	3	N/A	12	0x12	0	1028	4112	4	4112	1	(12+ 4096 + 1 + 3) 4112
PWI/MEFISTO	---	---	---	---	---	---	0x13							
MWE	---	---	---	---	---	---	0x14							
<b>DPU2-TOTAL</b>	<b>2050</b> <b>(tot:2090)</b>		<b>233MB</b> <b>(tot:251MB)</b>	<b>40</b>		<b>18.0MB</b>			<b>719987.2</b> <b>(720kB/s)</b>					

(5) DMC-DR Assignment: User-HK

(from MMO-MDP-DMCDR [JX-MMO-MDP-0004])

~ 20MB ~

User-HK			Size (MB)	Length (day)	Pac. Size (B)	Interval (sec)	Data rate (bps)	comment
	APID	Partition						
DPU1	0x619	32 (0x20)	7.56	14	800	256	25	Size / Rate: tbc
DPU2	0x621				800	256	25	Size / Rate: tbc
MPPE/MEA1	0x628	33 (0x21)	2.84		150	256	4.7	Size / Rate: tbc
MPPE/MEA2	0x630				150	256	4.7	Size / Rate: tbc
MPPE/MIA	0x638				150	256	4.7	Size / Rate: tbc
MPPE/MSA	0x640				150	256	4.7	Size / Rate: tbc
MPPE/HEP-e	0x648	34 (0x22)	1.42		150	256	4.7	Size / Rate: tbc
MPPE/HEP-i	0x650				150	256	4.7	Size / Rate: tbc
MPPE/ENA	0x658	35 (0x23)	0.71		150	256	4.7	Size / Rate: tbc
MGF-O	0x660	36 (0x24)	1.42		150	256	4.7	Size / Rate: tbc
MGF-I	0x668				150	256	4.7	Size / Rate: tbc
MDM	0x670	37 (0x25)	---		---	---	---	---
MSASI	0x678	38 (0x26)	0.71		150	256	4.7	Size / Rate: tbc
PWI/EWO-WFCE	0x680	39 (0x27)	2.36			200	256	6.3
PWI/EWO-WFCB								
PWI/EWO-EFD								
PWI/EWO-AM <sup>2</sup> P								
PWI/SORBET	0x690	ext: 40 (0x28)	0.71		150	256	4.7	Size / Rate: tbc
PWI/MEFISTO	0x698				150	256	4.7	Size / Rate: tbc
PWI/MWE (ext.)	0x6A0	40 (0x28)	0.71	150	256	4.7	Size / Rate: tbc	
<b>TOTAL</b>			<b>17.7 MB</b>				<b>117 bps</b>	

OneShot-HK			Size (MB)	Num. Packets	Pac. Size (B)	comment
	APID	Partition				
DPU1 / DPU2	0x619, 0x621	41 (0x29)	1.60	2000	800	Size / Rate: tbc
others	0x628, 0x630, 0x638, 0x640 0x648, 0x650, 0x658, 0x660 0x668, 0x670, 0x678, 0x680 0x690, 0x698, 0x6A0	42 (0x2A)	0.30	2000	150	Size / Rate: tbc
<b>TOTAL</b>			<b>1.9 MB</b>			



(6) DMC-DR Assignment: L-Mode & Continuous data >

(from MMO-MDP-DMCDR [JX-MMO-MDP-0004])

<i>TLM-Common &amp; L</i>			<b>Size (MB)</b>	<b>Compression Rate</b>	<b>Length (day)</b>	<b>Pac. Size (B)</b>	<b>Interval (sec)</b>	<b>Data rate (bps)</b>	<b>comment</b>
	<i>APID</i>	<i>Partition</i>							
<i>DPU1</i>	<i>0x619</i>	<i>50 (0x32)</i>	<b>Tbc</b>	<b>50%</b>	<b>7</b>	<i>Tbc</i>		<i>Tbc</i>	
<i>DPU2</i>	<i>0x621</i>		<b>tbc</b>			<i>Tbc</i>		<i>Tbc</i>	
<i>MPPE/MEA1</i>	<i>0x628</i>	<i>51 (0x33)</i>	<b>37.8</b>	<b>33%</b>		<i>Tbc</i>		<i>0.5kbps</i>	
<i>MPPE/MEA2</i>	<i>0x630</i>		<b>^</b>			<i>Tbc</i>		<b>^</b>	
<i>MPPE/MIA</i>	<i>0x638</i>		<b>^</b>			<i>Tbc</i>		<b>^</b>	
<i>MPPE/MSA</i>	<i>0x640</i>		<b>^</b>			<i>Tbc</i>		<b>^</b>	
<i>MPPE/HEP-e</i>	<i>0x648</i>	<i>52 (0x34)</i>	<b>^</b>	<b>50%</b>		<i>Tbc</i>		<b>^</b>	
<i>MPPE/HEP-i</i>	<i>0x650</i>		<b>^</b>			<i>Tbc</i>		<b>^</b>	
<i>MPPE/ENA</i>	<i>0x658</i>	<i>44 (0x2C)</i>	<b>22.7</b>	<b>33%</b>		<i>Tbc</i>		<i>0.3kbps</i>	
<i>MGF-O</i>	<i>0x660</i>	<i>53 (0x35)</i>	<b>10.6</b>	<b>50%</b>		<i>Tbc</i>		<i>0.14kbps</i>	
<i>MGF-I</i>	<i>0x668</i>	<i>54 (0x36)</i>	<b>^</b>			<i>Tbc</i>		<b>^</b>	
<i>MDM</i>	<i>0x670</i>	<i>45 (0x2D)</i>	<b>1.5</b>	<b>50%</b>		<i>Tbc</i>		<i>0.02kbps</i>	
<i>MSASI</i>	<i>0x678</i>	<i>46(A) (0x2E)</i>	<b>10.6</b>	<b>50%</b>		<i>Tbc</i>		<i>0.14kbps</i>	
<i>PWI/EWO-WFCE</i>	<i>0x680</i>	<i>55 (0x37)</i>	<b>24.5</b>	<b>50%</b>		<i>Tbc</i>			<i>0.39kbps</i>
<i>PWI/EWO-WFCB</i>		<i>56 (0x38)</i>	<b>^</b>						
<i>PWI/EWO-EFD</i>		<i>57 (0x39)</i>	<b>^</b>						
<i>PWI/EWO-AM<sup>2</sup>P</i>		<i>58 (0x3A)</i>	<b>^</b>						
<i>PWI/SORBET</i>		<i>59 (0x3B)</i>	<b>^</b>						
<b>TOTAL</b>			<b>112.7</b>						

(7) DMC-DR Assignment: M-Mode data

(from MMO-MDP-DMCDR [JX-MMO-MDP-0004])

<i>TLM- M</i>			<i>Size (MB)</i>	<i>Compression Rate</i>	<i>Length (day)</i>	<i>Pac. Size (B)</i>	<i>Interval (sec)</i>	<i>Data rate (bps)</i>	<i>Comment</i>	
	<i>APID</i>	<i>Partition</i>								
<i>DPU1</i>	<i>0x619</i>	<i>60 (0x3C)</i>	<b>Tbc</b>	<b>50%</b>	<b>7</b>	<i>Tbc</i>		<i>Tbc</i>		
<i>DPU2</i>	<i>0x621</i>		<b>Tbc</b>			<i>Tbc</i>	<i>Tbc</i>			
<i>MPPE/MEA1</i>	<i>0x628</i>	<i>61 (0x3D)</i>	<b>507</b>	<b>33%</b>		<i>Tbc</i>		<i>6.7kbps</i>		
<i>MPPE/MEA2</i>	<i>0x630</i>		<b>^</b>			<i>Tbc</i>	<b>^</b>			
<i>MPPE/MIA</i>	<i>0x638</i>		<b>^</b>			<i>Tbc</i>	<b>^</b>			
<i>MPPE/MSA</i>	<i>0x640</i>		<b>^</b>			<i>Tbc</i>	<b>^</b>			
<i>MPPE/HEP-e</i>	<i>0x648</i>		<i>62 (0x3E)</i>			<b>^</b>	<b>50%</b>	<i>Tbc</i>		<b>^</b>
<i>MPPE/HEP-i</i>	<i>0x650</i>	<b>^</b>		<i>Tbc</i>		<b>^</b>				
<i>MGF-O</i>	<i>0x660</i>	<i>63 (0x3F)</i>	<b>18</b>	<b>33%</b>		<i>Tbc</i>		<i>0.24kbps</i>		
<i>MGF-I</i>	<i>0x668</i>	<i>64 (0x40)</i>	<b>^</b>			<b>50%</b>	<i>Tbc</i>		<b>^</b>	
<i>MSASI</i>	<i>0x678</i>	<i>47(B) (0x2F)</i>	<b>53</b>			<i>Tbc</i>		<i>0.7kbps</i>		
<i>PWI/EWO-WFCE</i>	<i>0x680</i>	<i>65 (0x41)</i>	<b>^</b>	<b>50%</b>		<i>Tbc</i>			<i>3.7kbps</i>	
<i>PWI/EWO-WFCB</i>		<i>66 (0x42)</i>	<b>280</b>							
<i>PWI/EWO-EFD</i>		<i>67 (0x43)</i>	<b>^</b>							
<i>PWI/EWO-AM<sup>2</sup>P</i>		<i>68 (0x44)</i>	<b>^</b>							
<i>PWI/SORBET</i>		<i>69 (0x45)</i>	<b>^</b>							
<b><i>TOTAL</i></b>			<b>858</b>							
						<i>Tbc</i>		<b>^</b>		

(8) DMC-DR Assignment: H-Mode data

(from MMO-MDP-DMCDR [JX-MMO-MDP-0004])

*Total: 158MB x 6 = 948MB*

<i>TLM-H</i>			<i>Size (MB)</i>	<i>Compression Rate</i>	<i>Pac. Size (B)</i>	<i>Interval (sec)</i>	<i>Data rate (bps)</i>	<i>Comment</i>
	<i>APID</i>	<i>Partition</i>						
<i>DPU1</i>	<i>0x619</i>	<i>70/80/90/100/110/120</i>	<i>Tbc</i>	<i>50%</i>	<i>Tbc</i>			
<i>DPU2</i>	<i>0x621</i>	<i>(0x46/50/5A/64/6E/78)</i>	<i>Tbc</i>		<i>tbc</i>			
<i>MPPE/MEA1</i>	<i>0x628</i>	<i>71/81/91/101/111/121</i>	<i>3.4</i>	<i>33%</i>	<i>RAW:11.4MB for 20min</i>			
<i>MPPE/MEA2</i>	<i>0x630</i>	<i>(0x47/51/5B/63/6F/79)</i>	<i>3.4</i>		<i>RAW:11.4MB for 20min</i>			
<i>MPPE/MIA</i>	<i>0x638</i>		<i>11.9</i>		<i>RAW:39.6MB for 20min</i>			
<i>MPPE/MSA</i>	<i>0x640</i>		<i>12.4</i>		<i>RAW:42.4MB for 20min</i>			
<i>MPPE/HEP-e</i>	<i>0x648</i>	<i>72/82/92/102/112/122</i>	<i>2.3</i>	<i>50%</i>	<i>RAW: 4.6MB for 20min</i>			
<i>MPPE/HEP-i</i>	<i>0x650</i>	<i>(0x48/52/5C/66/70/7A)</i>	<i>41.5</i>		<i>RAW: 82.9MB for 20min</i>			
<i>MGF-O</i>	<i>0x660</i>	<i>73/83/93/103/113/123</i>	<i>1.2</i>	<i>33%</i>	<i>RAW: 2.4MB for 20min</i>			
		<i>(0x49/53/5D/67/71/7B)</i>						
<i>MGF-I</i>	<i>0x668</i>	<i>74/84/94/104/114/124</i>	<i>1.2</i>	<i>50%</i>	<i>RAW:2.4MB for 20min</i>			
		<i>(0x4A/54/5E/68/72/7C)</i>						
<i>PWI/EWO-WFCE</i>	<i>0x680</i>	<i>75/85/95/105/115/125</i>	<i>31.9</i>	<i>40%</i>	<i>RAW:79.8MB for 4min</i>			
		<i>(0x4B/55/5F/69/73/7D)</i>						
<i>PWI/EWO-WFCB</i>	<i>0x680</i>	<i>76/86/96/106/116/126</i>	<i>47.7</i>	<i>40%</i>	<i>RAW:119.2MB for 4min</i>			
	<i>0x690</i>	<i>(0x4C/56/60/6A/74/7E)</i>						
<i>PWI/EWO-EFD</i>		<i>77/87/97/107/117/127</i>	<i>0.8</i>	<i>50%</i>	<i>RAW:1.6MB for 20min</i>			
		<i>(0x4D/57/61/6B/75/7F)</i>						
<i>PWI/EWO-AM<sup>2</sup>P</i>		<i>78 (0x4E)</i>	<i>0.5</i>	<i>40%</i>	<i>RAW:1.2MB for 12s</i>			
<b><i>TOTAL</i></b>			<b><i>158</i></b>					